



Standard Access Agreement relating to Wholesale InterConnect and Symmetric Ethernet Products and Services and the National Broadband Plan

National Broadband Ireland

AND

[Service Provider]



SUBJECT TO CONTRACT/CONTRACT DENIED

This reference offer relates to the set of Wholesale InterConnect and Wholesale Symmetric Ethernet Services products outlined in the Project Agreement between National Broadband Ireland and DCCA as signed on 22nd November 2019. This product set includes InterConnect and Symmetric Ethernet Services product sets.

Version control

| Version | Status | Comments | Effective date |
|---------|--------|------------------------------|----------------|
| 1.0 | Active | Initial authorised version | 01/04/2020 |
| 1.1 | Active | Published authorised version | 01/04/2020 |
| 1.1.2 | Active | Published authorised version | 01/04/2020 |
| 1.1.3 | Active | Published authorised version | 01/04/2020 |
| 1.1.4 | Active | Published authorised version | 08/06/2020 |
| 2.0 | Active | Published authorised version | 07/01/2021 |

Glossary of Terms:

| | |
|--------|--|
| AF: | Assured Forwarding |
| API: | Application Programming Interface |
| BE: | Best Efforts |
| CIR: | Committed Information Rate |
| Co-Lo: | Co-Location |
| CPE: | Customer Premises Equipment |
| EF: | Expedited Forwarding |
| E-NNI: | External - Network to Network Interface |
| FTTH: | Fibre to the Home |
| IBH: | In-building Handover |
| ISH: | In-Span Handover |
| LAG: | Link Aggregation |
| LACP: | Link Aggregation Control Protocol |
| LAG: | Link Aggregation Groups |
| LER: | (MPLS) Label Edge Router |
| MMR: | Meet Me Room |
| MPLS: | Multi-Protocol Label Switching |
| NBI: | National Broadband Ireland |
| NTU: | Network Termination Unit |
| ODP: | Optical Distribution Point |
| OLT: | Optical Line Terminal |
| ONT: | Optical Network Terminal |
| PE: | Provider Edge node |
| PoH: | Point of Handover |
| PoP: | Point of Presence |
| SES: | Symmetric Ethernet Services |
| SP: | Service Provider (also known as RSP/WSP – Retail Service Provider) |
| UNI: | User Network Interface |
| VLAN: | Virtual Local Area Network |

SUBJECT TO CONTRACT/CONTRACT DENIED

VPLS: Virtual Private LAN Service
VUA: Virtual Unbundled Access
XGS-PON: 10Gbp/s Symmetric passive Optical Network

CONTENTS

| | Page No. |
|--|-----------------|
| 1 Introduction..... | 6 |
| 2 Commencement and Duration | 14 |
| 3 The Products and General Requirements..... | 14 |
| 4 Data Protection..... | 17 |
| 5 Charges, Billing and Payment..... | 17 |
| 6 Network Safety and Protection..... | 18 |
| 7 Interference | 18 |
| 8 Provisioning, Operation and Maintenance | 19 |
| 9 Resolution of Disputes | 19 |
| 10 Breach, Suspension and Termination | 20 |
| 11 Credit Assessment and Credit Risk Management | 22 |
| 12 Confidentiality | 22 |
| 13 Intellectual Property Rights | 23 |
| 14 Force Majeure | 23 |
| 15 Limitation of Liability | 25 |
| 16 Insurance..... | 25 |
| 17 Assignment of Rights and Obligations | 25 |
| 18 Minister Step-In | 26 |
| 19 Rights of Inspection, Reporting and Audit..... | 26 |
| 20 Notices..... | 27 |
| 21 Entire Agreement | 28 |
| 22 Waiver | 28 |
| 23 Severability..... | 28 |
| 24 Amendments | 28 |
| 25 Relationship of Parties | 28 |
| 26 Governing Law | 29 |
| Appendix 1 – Data Processing Agreement..... | 32 |
| Schedule 1 – InterConnect Product Description | 39 |
| Schedule 2 – Symmetric Ethernet Services Product Description | 50 |
| Schedule 3 – InterConnect and SES Product Billing | 57 |
| Schedule 4 – InterConnect Price List..... | 58 |

SUBJECT TO CONTRACT/CONTRACT DENIED

This **WHOLESALE INTERCONNECT AND SYMMETRIC ETHERNET SERVICES AGREEMENT** is made on [date]

BETWEEN

[], a company registered in Ireland with registration number [] and having its registered office at [Service Provider Address] (“Service Provider”);

and

NATIONAL BROADBAND IRELAND INFRASTRUCTURE DAC, a company registered in Ireland with registration number 631656 and having its registered office at 3009 Lake Drive, Citywest, Dublin 24, D24 H6RR (“NBI”),

(each of the Service Provider and NBI shall be referred to individually as a “Party” and together shall be referred to as the “Parties”).

1 Introduction

WHEREAS

- A. The Minister (as defined below) has appointed NBI to make certain wholesale Products (as defined below) available in the areas specified by the Minister in the NBP Agreement (as defined below).
- B. NBI has in turn agreed to provide the Service Provider with the Products on the terms of this Agreement.

This Agreement has been written in accordance with the Body of European Regulators for Electronic Communications (BEREC) Guidelines¹ and is assumed to be compliant with the proposed best practices set out in the BEREC Guidelines.

In consideration of the mutual covenant and obligations contained in this Agreement, the Parties **HEREBY AGREE AS FOLLOWS:**

Definitions and Interpretation

1.1 In this Agreement, words and expressions have the following meanings:

| | |
|---|---|
| “Affiliate” | means, in relation to a Party, a Subsidiary of that Party or a Holding Company of that Party or any other Subsidiary of that Holding Company. |
| “Agreement” | means the terms and conditions applicable to the provision of the Product as set out in this agreement and its Schedules (which may be updated by NBI from time to time and published on NBI’s website in accordance with the NBP Agreement and Clause 27 of this Agreement). |
| “Application Programming Interface” or “API” | means a set of routines, protocols and tools for building software applications. An Application Programming Interface specifies how the Service Provider and NBI software components should interact. |
| “Authorisation Regulations” | means the European Communities (Electronic Communications Networks and Services) (Authorisation) Regulations 2011 (SI 335 of 2011). |
| “Authorised Undertaking” | means an authorised undertaking as defined in the Authorisation Regulations. |
| “Best Industry Practice” | means the exercise of that degree of skill, diligence, prudence and foresight which would reasonably and |

¹ Body of European Regulators for Electronic Communications (BEREC) Guidelines on the Minimum Criteria for a Reference Offer, BEREC Document No. BoR 19 (238), 5th December 2019, available at: https://berec.europa.eu/eng/document_register/subject_matter/berec/regulatory_best_practices/guidelines/8899-berec-guidelines-on-the-minimum-criteria-for-a-reference-offer-relating-to-obligations-of-transparency

ordinarily be expected from a skilled, experienced and expert supplier in the Irish or United Kingdom electronic communications services and network industry and sector engaged to carry out and provide services, works, duties, deliverables, functions, responsibilities and activities of a similar scope, nature, scale, complexity and importance to the Services, Network and Products (or the relevant part of them) and under the same or similar circumstances or conditions and doing its best in good faith to comply with its contractual obligations and applicable Laws, Codes and Standards, Binding Guidance and Consents and, to the extent that it does not give rise to disproportionate or material cost, Non-Binding Guidance.

“Breach Notice”

means a written notice service by either Party on the other Party in the event of a breach of this as further described in Clause 16.

“Claim”

means any action, claim, demand, proceedings or similar.

“Clean Power Source”

means a power source which is electrical power that is free from voltage spikes and drops

“Co-Location Reference Offer”

means the specification, terms and conditions applicable to the Co-Location Product as set out in this Agreement, the Service Schedule entitled “Building and Cabin Co-Location Product” and as specified in the NBI Building and Cabin Co-Location Product Description, the NBI Building and Cabin Co-Location Access and Health & Safety Requirements, the NBI Building and Cabin Co-Location Service Level Agreement and the NBI Building and Cabin Co-Location Price List (all as published on the NBI website and as may be updated and re-published from time to time).

“Co-Location Product”

means the provision of sufficient rack space and other facilities including but not limited to AC power, DC power, air conditioning, at a Point of Handover.

“Co-Location Site”

means the premises, property or site at which or upon which the Co-Location Product is provided by NBI (as may be notified by NBI to the Service Provider from time to time).

“Commencement Date”

means the date on which this Agreement is executed and delivered by the Parties, namely the date first written above.

“Connection Request”

means a request from the Service Provider to NBI via the NBI Operational Environment to connect the Product to the Customer’s premises.

SUBJECT TO CONTRACT/CONTRACT DENIED

| | |
|---------------------------------------|--|
| “Customer” | means a person subscribing to the Service Provider Service, including without limitation, End Users, RSPs and WSPs. |
| “Department” | means the Department of Communications, Climate Action and Environment. |
| “Deployment Area (DA)” | means the geographical area that is served by an Optical Line Terminal (OLT) deployed by NBI for the purpose of providing Product(s) and Services to Premises located in that geographical area. |
| “E-Line” | means a service type for connecting two UNIs where those UNIs can communicate only with one another. |
| “E-LAN” | means a multipoint-to-multipoint service that connects a number of UNIs (2 or more) providing full mesh connectivity for those sites. Each UNI can communicate with any other UNI that is connected to that ethernet service. |
| “End User” | means the customer of the Service Provider on whose behalf the Service is ordered. |
| “Equipment” | means any equipment owned, leased or licensed by the Service Provider and used by the Service Provider in connection with its use of the Products. |
| “Holding Company” | means, in relation to a company or corporation, any other company or corporation in respect of which it is a Subsidiary. |
| “Incorrect Overpayment” | means a price that NBI charged to the Service Provider which was higher than the price which should have been charged in accordance with the Pricing Rules. |
| “Intellectual Property Rights” | means any patent, patent application, copyright, moral right, trade name, trade mark, service mark, trade secret, copyright, and any applications or right to apply for registration therefor, internet domain names, logos, designs, slogans, and general intangibles of like nature, computer software programs or applications, tangible or intangible proprietary information, know-how, proprietary processes, formulae, algorithms, or any other intellectual property right, whether registered or unregistered, and whether first made or created before, on, or after the date of this Agreement. |
| “InterConnect Product” | means, if applicable to the Service Provider, the InterConnect Product as described in more specific detail in this Reference Offer. |

SUBJECT TO CONTRACT/CONTRACT DENIED

“InterConnect and SES Product Process Manual” means the document published on NBI’s website that sets out the processes for Service Provider eligibility, ordering, fault management and billing for the Product.

“InterConnect and SES Product Technical Manual” means the document published on NBI’s website that provides a detailed description of the InterConnect and Symmetric Ethernet Service products that will be made available to Wholesale Service Providers (WSP) and Retail Service Providers (RSP/WSP).

“InterConnect and SES Service Level Agreement” means the document published on NBI’s website that sets out the degree of service and support that will be provided by NBI in respect of the Products and Services and the corresponding charges.

“InterConnect Product Price List” means the document that details the prices and charges for the Product as set out in Schedule 4 which may be updated from time to time by NBI and published on NBI’s website in accordance with the NBP Agreement and Clause 27 of this Agreement.

“Minister Representative” means such person or persons (or such substitute or substitutes) (other than the National Regulator) as may be appointed by the Minister under the NBP Agreement.

“Minimum Performance Specification” means as a minimum, the following indicators and related minimum performance:

- (i) minimum Download Speed between retail CPE and the internet demarcation point of 500 Mbit/s;
- (ii) minimum Upload Speed between retail CPE and the internet demarcation point of 50 Mbit/s;
- (iii) maximum Latency (round trip) between the retail CPE and the internet demarcation point of 100 ms;
- (iv) maximum Jitter between the retail CPE and the internet demarcation point of 50 ms;
- (v) maximum Packet Loss between the retail CPE and the internet demarcation point of 0.10%; and
- (vi) minimum end-to-end service availability of 99.95%

“National Regulator” means the Commission for Communications Regulation (ComReg) or any person or body designated as the National Regulatory Authority pursuant to Council Directive 90/388/ EEC.

“NBI Operational Environment” means the web portal and web services provided by NBI that can be accessed by the Service Provider to perform eligibility checks, place orders for Products, create or

“NBI Product and Commercial Team”

schedule appointments for End Users and create or track faults for End Users.

means the team of NBI staff reporting into the Chief Commercial Officer of NBI with responsibility for all Service Provider engagement activities and all Product management and development activities within NBI.

“NBP Agreement”

means the agreement entered into between NBI and the Minister under which the Minister appointed NBI to make certain wholesale services available in certain intervention areas, and references to the NBP Agreement are intended to reflect only NBI’s rights and obligations under the NBP Agreement and the Service Provider’s obligation to comply with same shall be limited to the extent the detail of the relevant provisions has been expressly incorporated into this Agreement, the Interconnect and SES Service Level Agreement, the Interconnect and SES Product Technical Manual and/or the Interconnect and SES Product Process Manual..

“Non-Compliant Overpayment”

means an amount equal to the difference between the Wholesale Price that NBI charged and the price which NBI should have charged in accordance with the Wholesale Pricing Rules over the total relevant period of non-compliance.

Means delivery of services outside published process and pricing where bespoke or customised service delivery elements are required by a WSP/RSP.

“Non-Standard Delivery”

“Onboarding Process”

means NBI’s process of onboarding RSP/WSPs to allow those RSP/WSPs to procure and avail of the Products.

“Optical Network Termination” or “ONT”

means wholesale customer premises equipment (WCPE), that is the network termination device located in the End User Premises that is used to terminate NBI’s Access Network and is the physical network termination point for the Wholesale Service Provider’s network and to which the Service Provider’s equipment is directly connected. The output of the WCPE provides the Demarcation Point between the NBI Network and the Service Provider’s equipment.

“Point of Hand Over” or “PoH”

means the point at which NBI hands over the conveyance of a Product to the Service Provider so that the Service Provider is then able to use a number of connection options to connect the PoH to its own network.

| | |
|---------------------------------------|--|
| “Prospective Customer” | means an entity or individual including without limitation End Users, RSPs and WSPs, that has requested to or wishes to subscribe to the Service Provider Service. |
| “Pricing Rules” | means the Wholesale Pricing Rules, Retail Pricing Rules, Price Benchmarking Rules and Wholesale Product Benchmarking Rules as set out in the NBP Agreement. |
| “Product(s)” | means each variant of the InterConnect and Symmetric Ethernet Service Products provided by NBI under this Agreement and as described in more detail in Schedules 1 and 2 and which may be updated by NBI from time to time in accordance with the NBP Agreement and published on NBI's website. |
| “Quarter” or “Quarterly” | means each three (3) month period during this Agreement from the Commencement Date onwards, with: the first Quarter commencing on the Commencement Date and ending on the last day of the third calendar month after which the Commencement Date falls (e.g. if the Commencement Date is 15 February, the Quarter commences on 15 February and ends on 30 April); and each subsequent Quarter being a period of three calendar months commencing on the day following the expiry of the preceding Quarter, with four (4) Quarters in each twelve (12) month period. |
| “Related Third Party” | means a person which is a party to another contract with the Service Provider which is relevant to this Agreement or is otherwise considered by NBI to be a Related Third Party for the purposes of a Dispute. |
| “Related Third Party Material” | means documents, data, information, video, graphics, sound, music, pictures, text, code, scripts, photographs, software and any other material (in whatever form) published or otherwise made available (directly or indirectly) by or on behalf of the Related Third Party using the Products. |
| “RSP(s)” | means a retail service provider including the Service Provider which has entered into a contract with NBI for the Products and will provide services to Customers or Prospective Customers. |
| “Service Provider Material” | means documents, data, information, video, graphics, sound, music, pictures, text, code, scripts, photographs, software and any other material (in whatever form) |

published or otherwise made available (directly or indirectly) by or on behalf of the Service Provider using the Products.

“SES Price List”

means the document that details the prices and charges for the Product as set out in Schedule 5 which may be updated from time to time by NBI and published on NBI’s website in accordance with the NBP Agreement and Clause 27 of this Agreement.

“Subsidiary”

means a company in respect of which another company, its holding company (i) holds a majority of the voting rights in it, (ii) is a member of it and has the right to appoint or remove a majority of its board of directors, or (iii) is a member of it and controls alone, pursuant to an agreement with other members, a majority of the voting rights in it, or if it is a subsidiary of a company that is itself a subsidiary of that other company.

“Standard Delivery”

Means delivery of services as per published process and pricing.

“Technical Manual”

means the technical document describing the InterConnect and Symmetric Ethernet Service Products.

“Third Party”

means any individual, company, firm, partnership, competent regulatory authority association or body corporate other than the Parties to this Agreement, or a Party to this Agreement acting in any capacity other than a capacity in which it enters into this Agreement.

“UNI”

means User Network Interface.

“VUA”

means Virtual Unbundled Access.

“Working Day”

means 08:00 – 20:00, during any day other than Saturdays, Sundays, or public holidays as defined in the Second Schedule to the Organisation of Working Time Act, 1997.

“Works”

means any works to be carried out by or on behalf of the Service Provider in connection with its use of a Product or the use by any Customer of a Service Provider Service.

“WSP(s)”

means a Wholesale Service Provider including the Service Provider which has entered into a contract with NBI for the Products and will provide services to End Users.

SUBJECT TO CONTRACT/CONTRACT DENIED

In this Agreement, except if the context requires otherwise, words and expressions are as defined in Clause 1.1 above or in the appropriate Schedule.

- 1.2 References to acts, statutory instruments and other legislation including European Union legislation are to such legislation as amended from time to time, any legislation of which it is a re-enactment and includes any subordinate legislation made from time to time under that legislation.
- 1.3 Terms defined in relevant European Union legislation concerning the provision of electronic communications networks and/or services or in consequent Irish implementing legislation (which, for the avoidance of doubt includes decisions published by the National Regulator) shall, where used in this Agreement, have the meanings ascribed to them in such legislation.
- 1.4 The following documents form part of this Agreement and, in the event of any inconsistencies between them, the order of precedence shall (unless expressly stated to the contrary) be as follows:
 - 1.4.1 Main body of the Agreement; and
 - 1.4.2 The provisions of the Schedules.

2 Commencement and Duration

- 2.1 This Agreement takes effect on the Commencement Date and shall continue until:
 - 2.1.1 the Service Provider ceases to be an Authorised Operator; or
 - 2.1.2 termination pursuant to this Agreement.

3 The Products and General Requirements

- 3.1 Schedules 1 and 2 provide a detailed description of the Products that NBI may provide under this Agreement. The terms of Schedules 1 and 2 are incorporated into this Agreement by reference.
- 3.2 The Service Provider shall not use a Product or allow or permit any Customer to use a Service Provider Service:
 - 3.2.1 other than in accordance with all applicable laws, including, but not limited to, the terms of any licence, approval, clearance or consent applicable to the Service Provider or the Customer (as applicable), data privacy laws, the laws of copyright and Intellectual Property Rights;
 - 3.2.2 in any way that contravenes the criminal law or to export or re-export any material in violation of any applicable export control laws and regulations;
 - 3.2.3 other than in accordance with the acceptable usage policies of the Service Provider and/or NBI;

SUBJECT TO CONTRACT/CONTRACT DENIED

- 3.2.4 to provide (at any fixed location) any retail broadband products or services that would not meet or exceed the Minimum Performance Specification;
 - 3.2.5 other than in accordance with any reasonable instructions and / or notice given by NBI; and/or
 - 3.2.6 other than in accordance with the provisions of this Agreement.
- 3.3 The Service Provider shall include and maintain in its contracts with Customers provisions which are no less onerous than those contained in this Agreement (including, for the avoidance of doubt, its Schedules).
- 3.4 The Service Provider shall exercise the reasonable skill and care of a competent electronic communications services provider in performing its obligations under this Agreement.
- 3.5 The Service Provider shall, insofar as required by Law, be solely responsible for ensuring any Service Provider Material and Related Third Party Material (in whatever form) complies with all applicable laws and regulations. The Service Provider further acknowledges and agrees that, save as required by Law, NBI has no responsibility in relation to any such Service Provider Material or Related Third Party Material (in whatever form).
- 3.6 The Service Provider shall provide NBI with a quarterly forecast of its projected number of Connection Requests and Pre-Ordered Connection Requests, broken out by Deployment Area (DA) Area, at least 20 Working Days in advance of each Quarter.
- 3.7 Subject to Clause 15, the Service Provider shall indemnify NBI, its employees, officers, servants and agents in full and on demand against any liability, fines, loss, cost, damage and expense (including but not limited to reasonable legal fees) incurred by it and arising directly from any Claim instituted or threatened against NBI by any Third Party in relation to:
- 3.7.1 the manner in which the Product has been used where such use is in breach of the provisions of this Clause 3;
 - 3.7.2 the Service Provider's installation and use of any equipment relating to the Products (including the Equipment);
 - 3.7.3 incidents (of material duration) in which the Service Provider Service is faulty or cannot be used by any Third Party (including a Customer);
- 3.7.4 to the extent the Service Provider is required by Law to be responsible for same, the content of data conveyed via the Products; and/or
- 3.7.5 the Service Provider Material or any Related Third Party Material which is provided to or made available to Customers or any other Third Party.

SUBJECT TO CONTRACT/CONTRACT DENIED

3.8 Subject to Clause 15, in the event that the use, maintenance, installation and / or removal of Equipment by or on behalf of the Service Provider causes any loss, damage, interference or disruption to any asset, equipment, installation, activities and / or operations of any Third Party ("**Third Party Damage**"), the Service Provider shall indemnify and hold NBI harmless from and against any Claim or proceeding arising out of or in connection with the Third Party Damage suffered by NBI (including Claims made against NBI by Third Parties resulting from the Third Party Damage) for each event or series of related events howsoever arising whether in contract, tort (irrespective of negligence) or from breach of duty (statutory or otherwise), except and insofar as NBI, its employees, servants or agents are directly liable therefore.

The indemnity under this Clause 3.8 shall include any Claim or proceedings arising out of or in connection with:

- 3.8.1 damage to Third Party equipment located at or in a Co-Location Site;
 - 3.8.2 all costs and expenses reasonably incurred in repairing and remediating the Third Party Damage;
 - 3.8.3 all costs and expenses reasonably incurred in taking such measures as are reasonably required to bring the asset, installation, equipment, activities and / or operations affected by the Third Party Damage back to normal order; and
 - 3.8.4 all Claims made or proceedings instituted against NBI by any Third Party in respect of the Third Party Damage.
- 3.9 The Products shall be made available to the Service Provider for the term set out for each Product in Appendix 1.
- 3.10 The Products provided by NBI will meet the service levels which are set out in the InterConnect and SES Service Level Agreement. In the event that the Service Provider does not meet the required service level, it shall be subject to penalties as set out in the InterConnect and SES Service Level Agreement.
- 3.11 The Service Provider shall obtain all and any licences, approvals, clearances or consents necessary over private land to use a Product or allow or permit any Customer to use a Service Provider Service, excluding any rights of way over public lands or any planning permissions.
- 3.12 Where the Service Provider is successful in obtaining permission for any Works, it shall provide NBI with all details of the permission and the Works shall not commence if the conditions attached to the permission are not acceptable to NBI (acting reasonably). If NBI has not notified the Service Provider that the conditions are unacceptable within 2 Working Days of receipt of the details of the permission, they shall be deemed to be acceptable.
- 3.13 Each Party shall use reasonable endeavours to mitigate its losses under this Agreement, including any losses under any indemnities set out in this Agreement.

4 Data Protection

This 'Data Protection' section should be read in conjunction with Appendix 1 of this document which details the 'NBI Data Processing Agreement' and its associated stipulations.

For the purposes of this Clause, "Data Protection Laws" means the General Data Protection Regulation (Regulation (EU) 2016/679) (the "GDPR"), (ii) the Data Protection Act 2018, and (iii) the European Communities (Electronic Communications Networks and Services) (Privacy and Electronic Communications) Regulations 2011, in each case as amended, supplemented or replaced from time to time; and the terms "processing", "controller", "data subject" and "personal data" have the meanings given to them in the GDPR.

To the extent that personal data of Customers is provided to NBI by the Service Provider pursuant to this Agreement, the Parties acknowledge and agree that Service Provider is the data controller and NBI is the data processor in respect of such personal data subject to Appendix 2. Each Party shall at all times comply with its obligations under applicable Data Protection Laws regarding such personal data.

The Service Provider shall ensure that it has provided all necessary notices to relevant data subjects, including but not limited to Customers (and to the extent applicable, obtained all necessary consents) to enable the lawful transfer of such personal data to NBI.

5 Charges, Billing and Payment

- 5.1 The Service Provider shall be liable to pay NBI for all charges and fees set out in the InterConnect and SES Price List set at Schedule 5 to this Agreement (the "Charges"). NBI reserves the right to update the InterConnect and SES Price List and publish it on NBI's Public Portal in accordance with the NBP Agreement.
- 5.2 The Charges shall be paid by the Service Provider at the billing intervals specified in the InterConnect and SES Price List. If no billing interval is specified, NBI shall issue invoices on an annual basis.
- 5.3 The Charges set out in the InterConnect and SES Price List are exclusive of value added tax ("VAT"). VAT shall be levied on all invoices issued pursuant to the terms of this Agreement at the appropriate VAT rate for each Product and such VAT will be payable by the Service Provider.
- 5.4 Invoices shall include detailed itemised billing of the Products provided and the relevant billing information.
- 5.5 Unless explicitly stated otherwise in this Agreement invoices are due and payable in EURO. Invoices are payable within thirty (30) Working Days from the date of issue the invoice unless provided otherwise in this Agreement.
- 5.6 The Service Provider shall pay each invoice by electronic transfer to a bank account nominated by NBI and notified to the Service Provider on the invoice in accordance with Clause 5.4.
- 5.7 Any disputes which arise in respect of the Charges or invoices shall be subject to the provisions of Clause 15 of this Agreement.

SUBJECT TO CONTRACT/CONTRACT DENIED

NBI shall refund to the Service Provider any Incorrect Overpayment or any Non-Compliant Overpayment (together with interest, as applicable) where required in accordance with the NBP Agreement.

- 5.8 Any undisputed amounts which are not paid when due shall accrue interest at a rate equal to 5% per annum over the base lending rate of the ECB ("**Interest Rate**") from the due date until the date of payment. If such unpaid sum is disputed in good faith and subject to a dispute resolution process in accordance with Clause 15 of this Agreement, interest shall accrue on such of the sum as is determined to be the proper sum due and payable at a rate equal to the Interest Rate from the date the disputed sum would have been due and payable had the sum not been disputed. Interest shall accrue daily but shall not be compound interest.

6 Network Safety and Protection

- 6.1 Each Party is responsible for the safe operation of its network and shall take all reasonable and necessary steps in its operation and implementation of this Agreement to ensure that its network does not

6.1.1 endanger the safety or health of employees, contractors, agents or customers of the other Party; or

6.1.2 damage, interfere with or cause any deterioration in the operation of the other Party's network.

- 6.2 Neither party shall connect nor knowingly permit the connection to its network of any equipment or apparatus, including, but not limited, to any terminal equipment, that is not approved by the relevant approvals authority for attachment to its network.

7 Interference

- 7.1 Where it is suspected that either parties' Equipment interferes with any other transmission or reception in such a way as to affect other services operating at the Co-Location Site then either party shall, on written request from either party, no later than twenty-four (24) hours after such request, use its best endeavours to prove the Equipment is not the cause of the interference. If the either party is unable to prove that the Equipment is not the cause of the interference within this period, then the Service Provider and NBI shall meet at the Co-Location Site and work together over a further twenty-four (24) hour period to ascertain whether the Equipment is the cause of the interference. If after this further twenty-four (24) hour period the interference remains and it has not been possible to prove that the Equipment is not the cause of the interference, then Clause 7.3.1 shall apply.

- 7.2 If the Equipment of either party is proven to be the cause of the interference, the relevant party shall take all necessary action to cease the interference as soon as possible but no later than one (1) Working Day after either party has served a written notice upon the other party requesting that such action be taken.

- 7.3 Where:

7.3.1 either party requests the other party comply with the provisions of Clauses 7.1 or 7.2; and

SUBJECT TO CONTRACT/CONTRACT DENIED

7.3.2 Either party fails to comply with that request within the periods as mutually agreed or as set out in the said clauses, as the case may be, or if in the case of a service affecting interference, referred to in Clause 7.1, the either party is unable to prove that the interference is not caused by the Equipment within the relevant notice period,

7.3.3 Either party shall be entitled to take any action in relation to the Equipment in whatever manner it deems appropriate and the offending party shall be liable to the injured party for all losses which they may suffer as a result of the failure by the offending party to comply with such a request.

8 Provisioning, Operation and Maintenance

The procedures for the provisioning of the Products and for the continuing operation and maintenance of the Products shall be as set out in the InterConnect and SES Process Manual as published on NBI's website and updated by NBI from time to time in accordance with the NBP Agreement.

9 Resolution of Disputes

9.1 If a dispute arises out of or in connection with this Agreement or the performance, validity or enforceability of it (a "**Dispute**"), then, except as expressly provided elsewhere in this Agreement, the Parties shall follow the procedure set out in this Clause:

9.1.1 either Party shall give to the other a written notice of the Dispute, setting out its nature and full particulars, together with relevant supporting documents (a "**Dispute Notice**"). On service of the Dispute Notice, the Account Manager of NBI and Product Manager (or person holding equivalent position) of Service Provider shall attempt in good faith to resolve the Dispute;

9.1.2 if the Account Manager of NBI and Product Manager (or person holding equivalent position) of Service Provider are for any reason unable to resolve the Dispute within twenty-five (25) Working Days of service of the Dispute Notice, the Dispute shall be referred to the Head of Product of NBI and Head of Product (or person holding equivalent position) of the Service Provider who shall attempt in good faith to resolve it.

9.2 The time limits specified above may be extended by mutual agreement between the Parties.

9.3 The above procedures are without prejudice to any rights and remedies that may be available to the Parties in respect of any breach of any provision of this Agreement.

9.4 Nothing in this Agreement shall prevent a Party from seeking (including obtaining or implementing) interlocutory or other immediate or equivalent relief.

9.5 Where the Service Provider invokes the provisions of this Clause after the due date of a disputed invoice, then the Service Provider shall not be entitled to withhold any portion of the amount due and payable. The Service Provider shall be entitled to raise a billing dispute within twenty-four (24) months of the end of the disputed billing period.

SUBJECT TO CONTRACT/CONTRACT DENIED

- 9.6 In the event either Party identifies an undetected billing error which may have resulted in either under or over billing with twenty-four (24) months of the billing period, the Party may raise this matter along with all relevant material and / or information. Upon review and consideration of the available information the Parties may issue a supplemental invoice or credit as appropriate.
- 9.7 Following resolution of the Dispute, the Parties will issue a credit or tender payment as appropriate.
- 9.8 Either or both Parties shall be entitled, provided that they have failed to resolve a Dispute in accordance with the provisions of this Clause 9.8 within the time limits specified or agreed for such resolution, to refer an unresolved Dispute to arbitration by a sole arbitrator. The arbitration shall be held in Dublin and shall be conducted in accordance with the arbitration procedure published from time to time by the Dispute Resolution Board of Engineers Ireland. Any such reference to arbitration shall be deemed to be a submission to arbitration within the meaning of the Arbitration Act 2010 or any statutory re-enactment or amendment thereof for the time being in force. The arbitrator shall be appointed by agreement between the Parties or, if such appointment has not been agreed within ten (10) Working Days of the referral of a Dispute to arbitration, by the President for the time being of the Institution of Engineers of Ireland (commonly known as “**Engineers Ireland**” or “**IEI**”) upon the request of either Party. Nothing in this Clause shall limit the rights of either Party to engage with the National Regulator for any relevant purpose.
- 9.9 In the event that the assistance or co-operation of the Service Provider is required in connection with any Dispute governed by the provisions of the NBP Agreement with which NBI is involved and which is relevant to the subject matter of this Agreement, the Service Provider shall provide any assistance and co-operation as may reasonably be required by NBI or the Minister in connection with such Dispute.

10 Breach, Suspension and Termination

- 10.1 If the Service Provider’s network adversely and materially affects the normal operation of the NBI network, or is a threat to any person’s safety, NBI may suspend, to the extent necessary, the provision to that Service Provider of any and all Products for such period as it may consider reasonable to ensure the normal operation of its network or to reduce the threat to safety.
- 10.2 If either Party is in material breach of this Agreement (including in relation to a failure by the Service Provider to pay an undisputed sum due hereunder within the required timeframe i.e. a sum which is not subject to the provisions of Clause 9), the other Party may serve a written notice on the Party in breach specifying the breach and requiring it to be remedied within:
- 10.2.1 25 Working Days from the date of receipt of such breach notice; or
- 10.2.2 in case of emergency (excluding financial obligations) within such shorter period as the Party not in breach may reasonably specify,
- (“Breach Notice”).**
- 10.3 If the Party fails to remedy the breach within the period stated in the Breach Notice, the other Party may terminate this Agreement by providing two (2) weeks’ written notice. If the Party in breach

SUBJECT TO CONTRACT/CONTRACT DENIED

- remedies the breach within such two (2) weeks' notice period, this Agreement shall not terminate as a result of such notice.
- 10.4 In the event the Service Provider fails to pay an undisputed invoice within the time provided in the Breach Notice, NBI may initiate credit vetting as defined in Clause 11 of this Agreement. The purpose of this vetting is to establish whether the non-payment is likely to cause a specific financial risk to NBI, due to the financial circumstances of the Service Provider.
- 10.5 If justified by credit vetting, NBI may request a financial security guarantee following the principles outlined in Clause 11. Failure (within the time specified in 11 or refusal (at any time) by the Service Provider to provide a financial guarantee shall give NBI the right to terminate this Agreement with seven (7) Working Days' notice.
- 10.6 This Agreement may be terminated immediately by either Party by written notice (or on the termination of such other period as such notice may specify) if the other Party:
- 10.6.1 is unable to pay its debts within the meaning of the Companies Acts 2014; or
- 10.6.2 has a receiver or examiner appointed or has been subject to an application for the appointment of a receiver or an examiner in relation to all or any of its assets or an encumbrancer has taken possession of all or a material part of its assets; or
- 10.6.3 has an order made or a resolution passed for its winding up (other than for the purpose of amalgamation or reconstruction); or
- 10.6.4 enters into a voluntary arrangement with creditors under the Companies Acts 2014; or
- 10.6.5 ceases to carry on business.
- 10.7 NBI shall be further entitled to terminate this Agreement immediately by notice in writing to the Service Provider if the Service Provider ceases to be an Authorised Operator.
- 10.8 The Service Provider may terminate this agreement at any time by giving NBI not less than twelve (12) months' written notice.
- 10.9 The Service Provider acknowledges that it shall not be entitled to any compensation upon the expiry or in the event of termination of this Agreement by NBI pursuant to the provisions of this Clause 10 and that upon such expiry or termination any sum due by the Service Provider to NBI shall become immediately payable.
- 10.10 The basis of NBI's right to make the Products available is the NBP Agreement. NBI shall have the right to (i) suspend or cease providing any or all of the Products; and (ii) terminate this Agreement where it is required to do so pursuant to the NBP Agreement (including under a remedial plan or to ensure compliance with the Pricing Rules).
- 10.11 Termination of this Agreement shall not be deemed a waiver of a breach of any term or condition of this Agreement and shall be without prejudice to a Party's rights, liabilities or obligations that have accrued prior to such termination.

11 Credit Assessment and Credit Risk Management

- 11.1 As part of the Onboarding Process, NBI shall be entitled to carry out credit vetting of a prospective Service Provider prior to (i) entering into this Agreement; or (ii) providing Products to a Service Provider. The Service Provider shall provide NBI with such information as NBI may request at any time for the purpose of determining the Service Provider's creditworthiness.
- 11.2 Should the result of the credit vetting of a prospective Service Provider confirm that the provision of the Products poses a financial risk which is greater than can be controlled by a credit limit, NBI may request a form of financial security. The level of security requested shall be proportional to the risk involved and may be provided by a means such as bank deposit or guarantee.
- 11.3 NBI may carry out credit vetting of an existing Service Provider where NBI has reasonable concern about the ability of the Service Provider to cover debts including without limitation where NBI has evidence of a poor payment history or the Service Provider's credit rating has been downgraded or threatened to be downgraded. The method to be used will be communicated to the Service Provider and will be standard to all Service Providers.
- 11.4 Should the result of credit vetting of an existing Service Provider confirm the existence of a financial risk, NBI has the right to request a form of financial security. The level of security requested shall be proportional to the risk involved and shall take due account of historic levels of payments, liability, payment frequency and credit terms. The financial security may be provided by a means such as bank deposit or guarantee, and NBI shall not unreasonably refuse to accept any other form of financial guarantee proposed by the Service Provider. The financial security will be subject to Quarterly review and will be removed or reduced where the security or its level is no longer justified. NBI reserves the right to treat failure to provide an agreed security within twenty-five (25) Working Days (or such longer period as NBI may reasonably allow) of the date of NBI's request as a breach of this Agreement.
- 11.5 NBI may, at any time, require the Service Provider to enter into bank or other guarantees or to provide some other form of financial security, (for example a deposit) which in the reasonable and fair opinion of NBI is/are appropriate as proportionate security against the possibility of the Service Provider's non-compliance with or non-observance of any of the provisions hereof (including failure to pay Charges due). NBI reserves the right to treat refusal to provide such security or failure to provide such security within twenty-five (25) Working Days (or such longer period as NBI may reasonably allow) of the date of NBI's request for the same as a breach of this Agreement by the Service Provider.
- 11.6 Credit terms are subject to review by NBI from time to time and NBI shall at all times have the right to suspend or vary any credit terms granted.
- 11.7 For avoidance of doubt, any Disputes relating to credit vetting and credit management shall be subject to the conditions set out in Clause 9 of this Agreement.

12 Confidentiality

- 12.1 Pursuant to this Agreement, a Party may be given access to or acquire information which is proprietary or confidential to the other Party and its Affiliates, clients and Customers. Any and all

SUBJECT TO CONTRACT/CONTRACT DENIED

such information obtained by either Party shall be deemed to be confidential and proprietary information. Each Party agrees to use the information solely for purposes of discharging obligations and exercising rights under this Agreement, to hold such information securely and in strict confidence and not to disclose such information to Third Parties or to use such information for any purposes whatsoever other than the provision and receipt of Products under this Agreement save where:

- 12.1.1 it is required on a need to know basis to its employees, agents, contractors or sub-contractors to ensure compliance with the provisions of this Agreement;
- 12.1.2 it is in the public domain other than in breach of this Agreement;
- 12.1.3 it is or becomes publicly available through no fault of the Service Provider; or
- 12.1.4 it is required to be disclosed by a government, regulatory or public service body (including the Minister and the Minister's duly appointed agents or delegates), National Regulator or a court or other comparable authority of competent jurisdiction; or
- 12.1.5 it is or has been created independently by or for the Party without use or knowledge of such Information,

provided that nothing in this Clause shall operate to prevent or preclude engagement by the Parties with the National Regulator or other regulatory authorities, in the exercise of a Party's rights and entitlements otherwise to engage with the National Regulator or other regulatory authorities.

13 Intellectual Property Rights

- 13.1 Except as expressly otherwise provided in this Agreement, Intellectual Property Rights shall remain the property of the Party creating or owning the same and nothing in this Agreement shall be deemed to confer any assignment or right or title whatsoever or licence of the Intellectual Property Rights of one Party to the other Party, and nothing in this Agreement shall be deemed to restrict the rights of any Party to own, use, enjoy, licence, assign or transfer its own Intellectual Property Rights.

14 Force Majeure

- 14.1 Neither Party shall be liable to the other Party for any delay in or failure to perform its obligation under this Agreement caused by a Force Majeure Event. For such purposes a "**Force Majeure Event**" means any event beyond the reasonable control of a Party, including act of God, insurrection or civil disorder, war or military operations, national or local emergency, acts or omissions of government, highway authority or other competent authority, compliance with any statutory, regulatory or legal obligation industrial disputes of any kind (whether or not involving either Party's employees), fire, lightning, explosion, flood, subsidence, weather of exceptional severity, outbreak of a viral animal disease in Ireland such as "foot and mouth disease" (in response to which the Government of Ireland has issued an order halting the operation of the relevant Party's business), acts or omission of persons for whom neither Party is responsible or any other cause whether similar or dissimilar outside its reasonable control.

SUBJECT TO CONTRACT/CONTRACT DENIED

- 14.2 The Party initially affected by a Force Majeure Event shall promptly notify the other of the circumstances in question and their effect on the performance of obligations under this Agreement, and the estimated extent and duration of its inability to perform or delay in performing its obligations ("**Force Majeure Event notification**").
- 14.3 Upon cessation of any service (including the provision of the Products by NBI and provision of the Service Provider Services) provided by the Party initially affected by a Force Majeure Event due to the effects of the Force Majeure Event that Party shall promptly notify the other of such cessation.
- 14.4 If as a result of a Force Majeure Event, the performance by the Party, initially affected, of its obligations under this Agreement is affected, such Party shall, subject to the provisions of Clause 14.6, perform those of its obligations not affected by a Force Majeure Event. In performing those of its obligations not affected by a Force Majeure Event, the Party initially affected by a Force Majeure Event shall deploy its resources such that (when taken together with other obligations to its customers and Third Parties) there is no undue discrimination against the other Party.
- 14.5 Each Party shall use its reasonable endeavours: (i) to avoid or remove the circumstances constituting a Force Majeure Event, and (ii) to mitigate the effect of the Force Majeure Event as and when it exists.
- 14.6 To the extent that a Party is prevented as a result of a Force Majeure Event from providing all of the Products to be provided under this Agreement, the other Party shall be released to the equivalent extent from its obligations to make payment for such Products or complying with its obligations in relation thereto.
- 14.7 Following a Force Majeure Event notification and if the effects of such Force Majeure Event continue for:
- 14.7.1 a continuous period of not more than 6 months from the date of the force majeure notification (whether or not notice of cessation has been given pursuant to Clause 14.3) any obligation outstanding shall be fulfilled by the Party initially affected by the Force Majeure Event as soon as reasonably possible after the effects of the Force Majeure Event have ended, save to the extent that such fulfilment is no longer possible or is not required by the other Party;
- 14.7.2 a continuous period of 6 months or more from the date of the Force Majeure Event notification (and notice of cessation has not been given pursuant to Clause 14.3, the Party receiving the Force Majeure Event notification shall be entitled (but not obliged) to terminate this Agreement by giving not less than thirty (30) Working Days written notice to the other Party, provided that such notice shall be deemed not to have been given if notice of cessation is received by the Party receiving the Force Majeure Event notification prior to the expiry of the thirty (30) Working Days' notice. If this Agreement is not terminated in accordance with the provisions of this Clause 14.7.2, any obligations outstanding shall be fulfilled by the Party initially affected by the Force Majeure Event as soon as reasonably possible after the effects of the Force Majeure Event have ended, save to the extent that such fulfilment is no longer possible or is not required by the other Party.

15 Limitation of Liability

- 15.1 If either Party is in breach of any of its obligations under this Agreement or otherwise (including liability for negligence or breach of statutory duty) such Party's liability to the other Party shall be limited to €1,250,000 (One million, two hundred and fifty thousand euro) in respect of any single incident or action which has given rise to a claim or up to a total of €2,500,000 (Two million, five hundred thousand euro) for greater than one incident within a 12 month period.
- 15.2 Neither Party shall be liable to the other in contract, tort (including negligence or breach of statutory duty) or otherwise for loss (whether direct or indirect) of profits, business or anticipated savings, wasted expenditure or for any indirect or other consequential loss whatsoever arising in connection with the operation of this Agreement, howsoever caused.
- 15.3 Each provision of this Clause 15 is a separate limitation applying and surviving even if one or more such provisions is inapplicable or held unreasonable in any circumstances.

16 Insurance

- 16.1 The Service Provider shall insure at its own cost, throughout the duration of this Agreement, its liability in respect of:
- 16.1.1 employer's liability; and
- 16.1.2 third party liability for loss, injury or damage,
- such insurances to carry a limit of indemnity of not less than €13,000,000 (thirteen million euro) per claim or series of claims arising from one event and unlimited in the aggregate.

17 Assignment of Rights and Obligations

- 17.1 Unless otherwise agreed in writing, and subject to Clause 17.2, no rights, benefits or obligations under this Agreement may be assigned or transferred, in whole or in part, by a Party without the prior written consent of the other Party. Such consent shall not be unreasonably withheld.
- 17.2 No consent is required under Clause 17.1 for an assignment of rights, benefits or obligations under this Agreement (in whole or in part) to an Affiliate of the assigning Party provided that:
- 17.2.1 such Affiliate is legally authorised to operate the network of the assigning Party;
- 17.2.2 the assigning Party shall promptly give notice to the other Party of any proposed assignment; and
- 17.2.3 no assignment shall be valid unless the assignee / successor agrees in writing to be bound by the provisions of this Agreement.
- 17.3 Nothing in this Agreement shall prevent NBI from novating or assigning its right and obligations under this Agreement to the Minister or a replacement supplier where required to do so under the terms of the NBP Agreement.

18 Minister Step-In

- 18.1 The Service Provider recognises and agrees to comply with all of the Minister's step-in rights under the NBP Agreement ("**Step-In Rights**"). In the event that the Step-In Rights are invoked by the Minister in accordance with the NBP Agreement, the Minister will be entitled to take certain actions including the right to assume (either itself or through the appointment of a suitable Third Party) the rights and obligations of NBI pursuant to this Agreement.

19 Rights of Inspection, Reporting and Audit

- 19.1 Subject to the provisions of this Clause, the Service Provider shall at all times permit NBI or the Minister's representatives (including external auditors or advisors) (together, the "**Auditors**") to have access to:

19.1.1 the business records maintained by the Service Provider relating to the Products;

19.1.2 the Service Provider site(s) where the Service Provider Services using the Products are performed;

19.1.3 the Service Provider personnel who are passing the benefit of the Products to the Customers;

19.1.4 copies of Service Provider internal reports (including internal audit reports) relating to the provision of the Service Provider Services using the Products;

19.1.5 Service Provider's business premises in order to inspect any one of the above;

19.1.6 any additional information and / or documentation in connection with this Agreement that is reasonably required to be reported to the Minister pursuant to the terms of the NBP Agreement, including information in relation to the operational performance of the Products under this Agreement.

- 19.2 The Service Provider agrees to provide the Auditors with access to and / or copies of any information requested pursuant to this Clause 19.2 within five (5) Working Days from the time of any such request.

- 19.3 On an annual basis, the Service Provider will participate in and respond to NBI's reasonable information security questionnaire processes.

- 19.4 Upon reasonable request, the Auditors will arrange for their relevant subject matter experts to meet with the relevant subject matter experts of the Service Provider to review Service Provider's security controls and any deficiencies identified in same. The Auditors may view Service Provider's security-related policies and procedures, however, no documentation may be copied, shared, transmitted or removed from the Service Provider's premises, except as mutually agreed or required by applicable law.

- 19.5 Not more than once each year, and subject to the Service Provider's reasonable security requirements and availability of personnel (which shall be secured as soon as reasonably possible),

SUBJECT TO CONTRACT/CONTRACT DENIED

Service Provider will at the Auditor's request arrange a tour of Service Provider's facilities for Auditors subject matter experts. In the event that an Auditor identifies any technical or operational deficiencies, Service Provider will discuss such findings with the Auditor and the parties shall work together to develop a mutually agreeable remediation plan.

19.6 All non-public documentation and information disclosed to an Auditor in accordance with this Clause shall be deemed proprietary and confidential information of Service Provider. The Auditor shall not disclose such documentation or information to any Third Party or use it for any purpose other than evaluating Service Provider's security controls, except (1) as may be permitted under the terms of this Agreement (including Clause 12 (Confidentiality)) and (2) that an Auditor may disclose information gained from the security questionnaire processes to its own external auditors and advisors provided that such external auditors and advisors are required to be bound by confidentiality obligations that are at least equivalent to those assumed by the Auditor disclosing such information.

19.7 The Service Provider will ensure that all information and materials to be provided to the Auditors pursuant to this Clause 19.7:

19.7.1 will be kept in a form that is reasonably capable of audit pursuant to this Clause 19;
and

19.7.2 will to the best of its knowledge, information and belief, be true, correct and accurate and will not be false or materially misleading in any way.

19.8 Without prejudice to any other audit right, NBI shall undertake no more than one audit and two spot checks pursuant to this Clause 19 in each calendar year of the Agreement unless otherwise required by the Minister or the Minister's Representative.

20 Notices

20.1 A notice shall be duly served if:

20.1.1 delivered by hand, at the time of actual delivery;

20.1.2 sent by facsimile, upon its receipt being confirmed;

20.1.3 sent by recorded delivery post, two (2) Working Days after the day of posting.

20.2 Except if otherwise specifically provided all notices and other communications relating to this Agreement shall be in writing and shall be sent as follows:

20.2.1 If to the Service Provider [Telephone 01 xxxxxx Address, Facsimile 01 yyyyyyy]; and

20.2.2 If to NBI: Wholesale Contracts Manager, National Broadband Ireland, 3009 Lake Drive, Citywest, Dublin 24, D24 H6RR with carbon copy to the Head of Product at SP_engagement@nbi.ie.

SUBJECT TO CONTRACT/CONTRACT DENIED

or to such other addresses as the Parties may notify from time to time pursuant to this Clause 20 (Notices).

21 **Entire Agreement**

This Agreement represents the entire understanding of an agreement between the Parties in relation to the subject matter of this Agreement, and, unless otherwise agreed in writing, supersedes all previous understandings, commitments, agreements or representations whatsoever, whether oral or written.

22 **Waiver**

The waiver of any breach of, or failure to enforce, any term or condition of this Agreement shall not be construed as a waiver of any other term or condition of this Agreement. No waiver shall be valid unless it is in writing and signed on behalf of the Party making the waiver.

23 **Severability**

The invalidity, unenforceability of any provision of this Agreement shall not affect the validity or enforceability of the remaining provisions of this Agreement.

24 **Amendments**

24.1 Any amendments, including changes to the Charges or changes to the Products required in order to give effect to NBI's rights or obligations under the NBP Agreement or specified by directions, decisions determinations, specific obligation, obligations, measures and requirements of the National Regulatory or other competent regulatory or statutory body, shall be deemed to be automatically incorporated into this Agreement with immediate effect or on such alternative date as specified by NBI, the Minister or a Minister Representative. In particular, the (i) Charges; or (ii) the nature of the Products, may be changed from time to time and published on NBI's website where NBI is required to make such changes under the terms of the NBP Agreement.

24.2 Notwithstanding Clause 24.1, the automatic incorporation of changes in the Agreement shall apply only to the Party subject to the obligations and to extent that the mandating body has jurisdiction to impose such obligations.

24.3 All other changes to this Agreement shall be in writing and agreed between the Parties to become effective and binding upon the Parties.

25 **Relationship of Parties**

25.1 The relationship between the Parties is that of independent contractors. Nothing in this Agreement shall be construed to make either Party hereto an agent, joint venture or partner of or with the other. Neither Party is granted any right of authority or agency, expressly or implicitly, on behalf of, or in the name of, the other, nor any right to legally bind the other in any manner whatsoever. Neither Party shall become liable through any representation, act or omission of the other which is contrary to or unauthorised by the provisions of this Agreement. Nothing in this Agreement shall be treated or construed as creating the relationship of landlord and tenant between the Parties.

26 **Governing Law**

The interpretation, validity and performance of this Agreement shall be governed in all respects by the laws of Ireland and the Parties submit to the exclusive jurisdiction of the Irish Courts.

IN WITNESS WHEREOF THIS AGREEMENT WAS ENTERED INTO THE DAY AND YEAR FIRST ABOVE WRITTEN.

SUBJECT TO CONTRACT/CONTRACT DENIED

Signed for and behalf of **NBI INFRASTRUCTURE DAC**

Signature

Name (block capitals)

Title

Date

AND

Signed for and behalf of **NBI INFRASTRUCTURE DAC**

Signature

Name (block capitals)

Title

Date

SUBJECT TO CONTRACT/CONTRACT DENIED

Signed for and behalf of **[SERVICE PROVIDER]:**

Signature

Name (block capitals)

Title

Date

Appendix 1 – Data Processing Agreement

THIS DATA PROCESSING AGREEMENT IS MADE BETWEEN:

- (1) **NBI INFRASTRUCTURE DAC**, a company registered in Ireland, with company number 631656 having its registered office at 3009 Lake Drive, Citywest, Dublin 24, D24 H6RR (“**NBI**”)
- and
- (2) [], a company incorporated in Ireland whose registered office is at [] (the “**RSP**”).

BACKGROUND:

- A. Each Party is an Authorised Undertaking for the provision of electronic communication networks and services in Ireland pursuant to the Authorisation Regulations.
- B. NBI and the WSP/RSP entered into the Agreement on or around [] for the provision by NBI of certain broadband services to the WSP/RSP for the purposes of offering such broadband services to End Users.
- C. In the ordinary course of providing or receiving such services the Parties will be required to process, transmit and/or share Customer Personal Data. Further to the Agreement, the Parties agree to the provisions of this data processing agreement (the “**DPA**”) for the purposes meeting their respective obligations to each other under the Agreement and the Data Protection Laws in relation to such processing activities in respect of the Customer Personal Data.
- D. In particular, in connection with the RSP’s provision of the Service Provider Services, the RSP will provide certain Customer Personal Data to NBI in order to enable NBI to undertake certain data processing activities as a processor on behalf of RSP.

THE PARTIES AGREE as follows:

1. DEFINITIONS

In this DPA all defined terms in the Agreement shall apply. To the extent not otherwise defined in the Agreement, the following terms shall have the following meanings:

“**Agreement**” means the Agreement between NBI and the RSP.

“**Authorisation Regulations**” means European Communities (Electronic Communications Networks and Services) (Authorisation) Regulations 2011 (SI 335 of 2011);

“**Customer Personal Data**” shall in particular have the meaning as described in in the Data Processing Schedule 1, which forms part of this DPA;

“**Minimum Security Requirements**” shall mean the security measures specified in the Data Processing Schedule 2, which forms part of this DPA, as may be updated or reissued from time to time by the Parties in accordance with the terms of the Agreement;

“**Processing Purposes**” has the meaning as described in in the Data Processing Schedule 1, which forms part of this DPA;

“**Relevant Personnel**” means the Data Processor’s employees, agents and personnel and such other personnel of the Data Controller as may be approved in writing by the Data Controller from time to time in respect of access to the Personal Data;

“**Services**” shall mean the Service Provider Services as described in the Agreement;

“**Standard Contractual Clauses**” shall mean the model contract clauses set out in the European Commission’s Decision of 5 February 2010 on standard contractual clauses for the transfer of Personal Data to Processors established in third countries, under the Data Protection Directive as may be amended by the European Commission from time to time; and

“**Supervisory Authority**” shall mean the Irish Data Protection Commission or any other competent data protection supervisory in accordance with the GDPR.

2. APPLICATION OF TERMS OF THIS DPA

2.1. The Parties agree that terms of this DPA shall apply to and govern NBI’s processing of Customer Personal Data where, in accordance with clause 6 of the Agreement, NBI acts as a processor on behalf of the RSP acting a controller.

2.2. To the extent that NBI processes Customer Personal Data independently of the Agreement, including where NBI obtains Customer Personal Data directly from End Users or subjects separate to the Agreement, NBI will in such circumstances act as an independent controller and, in doing so, shall comply with its obligations under Data Protection Laws.

3. DURATION

The provisions of this DPA shall apply from the Commencement Date for the duration of the Agreement and shall continue to apply to any processing of Customer Personal Data undertaken by NBI on behalf of the RSP after the termination of the Agreement.

4. DATA PROCESSING OBLIGATIONS

4.1. From the Commencement Date, where NBI processes Customer Personal Data provided to it by or on behalf of the RSP, as a processor in connection with the Processing Purposes, NBI agrees that it:

4.1.1. shall process Customer Personal Data only for the Processing Purposes in connection with the provision of the Services, as described in Schedule 1 of this DPA, or as subsequently instructed in writing from time to time by the RSP;

4.1.2. shall ensure that it shall not transfer the Customer Personal Data outside the European Economic Area (“**EEA**”) without the express written instructions of the RSP and where such instructions are received by NBI, such transfers of Customer Personal Data shall be undertaken in accordance with the Data Protection Laws;

4.1.3. shall ensure that all Relevant Personnel authorised to be involved in the processing of Customer Personal Data for and on behalf of NBI have committed themselves to a duty of confidentiality in respect of Customer Personal Data;

4.1.4. shall implement appropriate technical and organisational measures in accordance with Article 32 of the GDPR to ensure the security of Customer Personal Data, in particular as described in Minimum Security Requirements under Data Processing Schedule 2 of this DPA;

4.1.5. shall only engage sub-contract or outsource the processing of Customer Personal Data under this DPA to any other person or Third Party processor (“**Sub-processor**”) subject to:

(i) having notified the RSP of the identity of such Sub-processor and obtaining the written authorisation of the RSP before engaging any such Sub-processor; and

(ii) NBI putting in place binding contractual terms with such Sub-processor on terms no less onerous than those contained in this DPA;

4.1.6. taking into account the nature of the processing of Customer Data, NBI shall reasonably assist the RSP in meeting its responsibilities as a controller by putting in place appropriate technical and organisational measures to enable NBI to provide reasonable assistance on request from RSP in responding to any data subject requests received by the RSP in accordance with the Data Protection Laws;

4.1.7. on becoming aware of a “personal data breach” (as such term is defined in the Data Protection Laws) affecting the Customer Personal Data, NBI shall notify the RSP without undue delay and in any event within a period of 24 hours using the following contact details:

| | | |
|---------------------|-----|-----|
| RSP email addresses | [●] | [●] |
| RSP phone number | [●] | [●] |

4.1.8. on becoming aware of a personal data breach affecting Customer Personal Data, NBI shall provide reasonable assistance to the RSP in investigating and remediating any such incident(s);

4.1.9. depending on the nature of the processing activities, NBI shall not retain Customer Personal Data for any longer than is necessary having regard to the Processing Purposes;

4.1.10. on request, NBI shall reasonably assist the RSP in ensuring compliance with the RSP’s obligations to comply with Articles 32 to 36 of the GDPR (inclusive);

4.1.11. based on written instructions of the RSP, either return or securely delete the Customer Personal Data on the termination of the Agreement and relevant processing of Customer Personal Data. If NBI has not received instructions from RSP return or delete the Customer Personal Data within received within 25 Working Days of the effective date of termination of the Agreement, NBI shall by default delete the Customer Personal Data.

4.1.12. on written request, it shall make available to the RSP all information strictly necessary for the WSP/RSP to demonstrate compliance with its obligations under Article 28 of the GDPR, including records of the processing undertaken by NBI of the Customer Personal Data, on receipt of reasonable notice of not less than 10 Working Days;

4.1.13. on written request from the RSP, NBI shall contribute to audits, including inspections, conducted by or on behalf of the RSP of NBI’s relevant data processing facilities, data files, procedures or documentation as is strictly necessary for the RSP to demonstrate its compliance with the Data Protection Laws as they relate to the processing of Customer Personal Data. Any such right of audit is subject to the conditions that:

(i) the RSP shall provide notice of not less than 20 Working Days in advance of any such audit;

SUBJECT TO CONTRACT/CONTRACT DENIED

- (ii) any such auditor nominated by the RSP must be independent, impartial and suitably qualified and must be acceptable to NBI and not, in NBI's reasonable opinion, present any conflict of interest or be a competitor of NBI;
- (iii) any such auditor, including a Third Party auditor nominated by the RSP, must commit itself to a written duty of confidentiality; and
- (iv) the RSP shall be permitted to undertake no more than one such audit in any 12-month period (save in exceptional circumstances, where the RSP is compelled to do so based on binding request from a Supervisory Authority).

4.2. For the purposes of Clause 4.1.5 above, the RSP hereby authorises the appointment of the appointed NBI connection company as Sub-processor on behalf of NBI to process Customer Personal Data for the purposes of providing certain of the Services.

4.3. Any additional costs incurred by NBI (which in NBI's view, acting reasonably exceed the costs reasonably contemplated by it) in order to ensure compliance with clauses 4.1.6, 4.1.8 and 4.1.10 shall be at the expense of the RSP. NBI shall provide written evidence in support of such costs incurred by it when requesting re-imbursement of such costs.

5. DATA CONTROLLER OBLIGATIONS

5.1. The RSP shall provide Customer Personal Data to NBI only to the extent necessary to enable NBI achieve the Processing Purposes and in this regard the RSP shall not provide any excessive or unnecessary Customer Personal Data to NBI. All Customer Personal Data provided by the RSP to the NBI shall be accurate and up to date.

5.2. The RSP acknowledges that NBI is reliant on the RSP for lawful instruction as to the extent of the NBI's processing of Customer Personal Data and accordingly the RSP agrees to provide clear written instructions in a timely manner to NBI, which shall at all times be in compliance with the Data Protection Laws.

5.3. Notwithstanding clause 5.2 above, NBI retains the discretion to refuse any such instruction received if, in NBI's reasonable opinion, such instruction infringes the Data Protection Laws or any other applicable law. In such circumstances, NBI shall notify in writing the RSP of same, including the reasons underlying its opinion.

5.4. As regards access to the NBI Operational Environment, the RSP shall ensure that its staff, employees, contractors and all other personnel authorised to access NBI Operational Environment, shall ensure the security and confidentiality of all passwords, credentials and access

SUBJECT TO CONTRACT/CONTRACT DENIED

codes. The RSP shall maintain an up to date list of all persons authorised by it to access, upload and download data to and from the NBI Operational Environment.

6. APPLICABLE PROVISIONS

- 6.1.** To the extent there is any conflict between the provisions of this DPA and the Agreement concerning the processing of Customer Personal Data, the provisions of this DPA shall in all such cases prevail over the provisions of the Agreement.

- 6.2.** Subject to clause 6.1 above, all other provisions of the Agreement shall continue to apply and govern the provision of the Services.

DATA PROCESSING SCHEDULE 1 OF DPA

DESCRIPTION OF CUSTOMER PERSONAL DATA AND PROCESSING PURPOSES

| | |
|--|---|
| <p>1. Categories of Data Subject</p> | <p>The data subjects are comprised of End Users of the broadband services provided by the RSP (and in some limited cases, neighbours, friends or other points of contact for purposes of facilitating appointments).</p> |
| <p>2. Categories of Customer Personal Data</p> | <p>- Contact details: End-User names, personal addresses and contact telephone numbers (including mobile and/or landline) (together “End User Contact Details”); and</p> <p>- Appointment information: Details of appointments / orders to perform eligibility check-ups and place orders from End Users (together “Appointment Information”).</p> |
| <p>3. Duration of processing</p> | <p>See clause 3 of the DPA.</p> |
| <p>4. Processing Purposes</p> | <p>A. General purpose: NBI will provide a web portal and web services that RSP will access to perform eligibility checks, place orders for the Services, create/schedule appointments for End Users, create/track faults for End Users.</p> <p>B. Specific data processing: The NBI operational environment is used to connect NBI RSPs with NBI in order to deliver the Services to End Users. The following data flows are applicable:</p> <ol style="list-style-type: none"> 1. RSP provides contact details to NBI for appointment reservation purposes; 2. NBI’s poll gateway for work orders, which contain the contact details from the appointment reservation; and 3. If an RSP is viewing work orders for the Services or appointments on NBI portal front-end, then this data would go over VPN between the RSP and NBI’s platform. |
| <p>5. Physical location of Customer Personal Data</p> | <p>Amazon web services (servers located within the EEA).</p> |

**DATA PROCESSING SCHEDULE 2 OF DPA
MINIMUM SECURITY REQUIREMENTS**

NBI shall in particular implement the following technical and organisational security measures to ensure the security of Customer Personal Data:

1. Encryption-at-rest: Personal Data for appointments will be encrypted (by https and SSL certs) web services and portal access to this data (whether submitting or viewing via the NBI operational environment).
2. Encryption-at-rest: Similarly, the web services used by retail service provider (RSP) to access this information will also be encrypted (HTTPs and SSL certs).
3. Encryption-in-transit: All access to BSS data – whether by Managed Service Front-End or Web Services will be encrypted in transmission.

Schedule 1 – InterConnect Product Description

1. InterConnect Wholesale Product Overview

The NBI InterConnect Product enables the handover of NBI Bitstream and VUA traffic over the same InterConnect. The traffic can be aggregated together for handover at a specific PoH.

There are three variants of the Interconnect Product that can be ordered on the NBI Service Provider Portal. The three variants are:

- Third Party Premises (TPP) InterConnect also called Customer-Sited Handover (CSH)
- In-Building InterConnect (IBH)
- In-Span InterConnect (ISH)

Each InterConnect Product comprises of two components:

- Physical Interconnect
- Logical Interconnect

Both the physical and logical components have a separate and unique Identifier Code with an identifying prefix to ensure easier recognition of the circuit type to assist with reporting and fault handling. The Identifier Codes are used on all Bitstream, VUA and SES orders. The InterConnect Identifier Code is in the format: **NBIXxxxxxx**.

NBI is responsible for the provision, repair and maintenance of the InterConnect from the NBI aggregation equipment node to the demarcation Point of Handover (PoH).

Service Providers are responsible for connectivity between the PoH and the Service Provider equipment, and any end-to-end testing of their service. Service Providers must ensure that a suitable environment is provided, at their own expense, with adequate space, power, environmental conditions and general facilities available to allow NBI to deliver the InterConnect service for TPP and IBH InterConnects.

For IBH the demarcation point is the patch panel in NBI's rack. the Service Provider is responsible for the request, provision and support of the cross connect to connect the Service Providers equipment to NBI's InterConnect and for the payment of any cross connect charges.

The Service Provider should review and manage their bandwidth requirements and have their requirements submitted in the quarterly forecast.

1.1. Pre-Ordering Requirements

1.1.1. Quotations

Service Providers can use the Service Portal quotation tool to determine the cost of the InterConnect Product.

1.1.2. TPP / ISH InterConnect

There are no pre-ordering requirements for Third Party Premises and In-Span InterConnects. A physical survey may, however, be required by NBI at the start of each order.

1.1.3. IBH InterConnect

Service Providers must have purchased the Co-Location product with allocated Co-Location rack space before they can request a cross connect to the NBI patch panel for the InterConnect Product.

The IBH product can be used where the NBI Co-Location is in a Data Centre. In this case, the Service Provider must separately pay for their Data Centre cross connect in the Meet Me Room (MMR) directly to the relevant Data Centre owner.

1.1.4. ISH InterConnect

The demarcation point for an ISH InterConnect is the ODF in NBI's standoff chamber. Service Providers will meet NBI in the nominated chamber. The Service Provider is responsible for the request, provision and support of any dark fibre required to meet NBI in their chamber. The Service Provider is also responsible for the payment of any dark fibre charges required to Interconnect in NBI's chamber.

1.1. InterConnect Products

Handover of traffic is achieved by means of a number of InterConnect products as set out in the below sections:

1.1.1. Handover by means of Third Party Premises InterConnect (TPP)

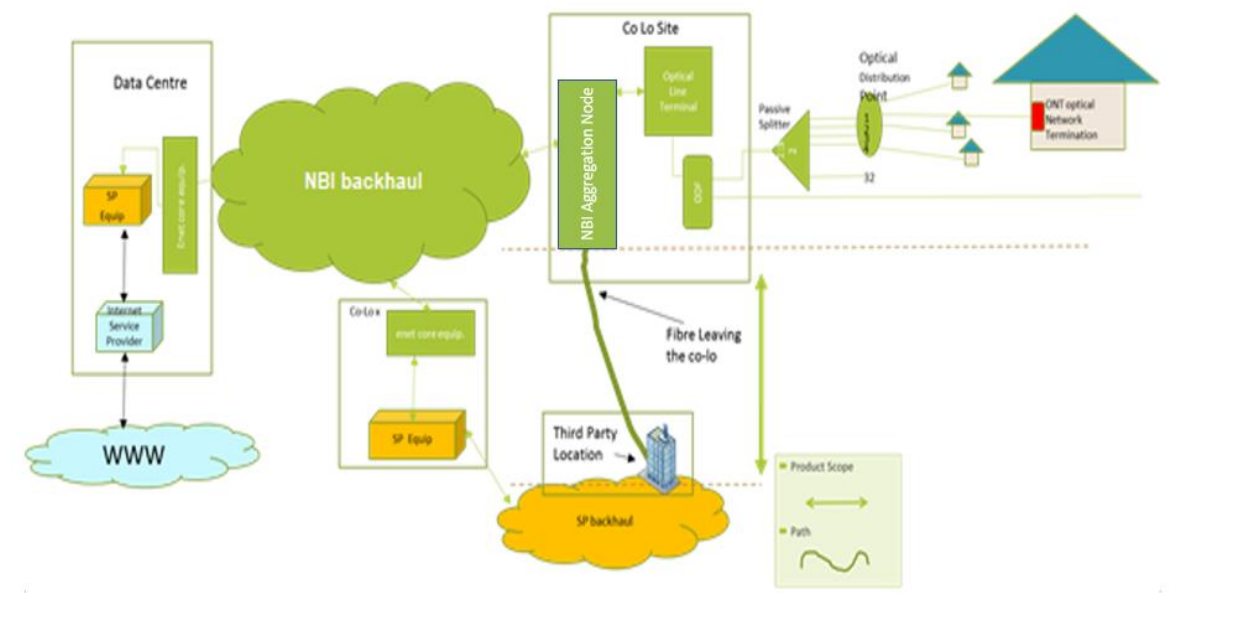

Figure 1: Third Party Premises InterConnect

The physical access is delivered on an optical fibre connection from the NBI Co-Location point to the Service Provider PoH located at a Third Party Premises. Figure 1 above shows the fibre connected from the aggregation node in the Co-Location site to the Third Party Premises. For non-standard delivery, the order is subject to a full site survey and excess charges may apply.

The TPP InterConnect will be delivered using an NTU via single mode hand fibre. The NTU is designed to take AC/DC single power or dual power supply and be installed in the Third Party Premises. The demarcation point is the Service Provider's port on the NTU.

For a non-standard order, the Service Provider will be responsible for any costs associated with pole / duct work within the curtilage of the Third Party's location and within the Third Party premises itself.

When the external route from the curtilage to the premises is completed, NBI will run a fibre from the curtilage to the Third Party location. If pole access is used, a suitable break-in point will need to be identified. The Service Provider is responsible for drilling into the building.

If duct / pole route is available but the duct / pole is not owned by NBI then the Service Provider must arrange for approval for NBI to use the Third Party infrastructure (Wayleave approval and costs). Any costs associated with this will be incurred by the Service Provider.

SUBJECT TO CONTRACT/CONTRACT DENIED

The Service Provider is responsible for providing a suitable internal Cable Management System (CMS) from the premises fibre entry point to the NTU location. It is also responsible for providing a suitable NTU location with a Clean Power Source. NBI run the fibre to the NTU and install the NTU. The same SFP / XFP type should be installed at both ends of the fibre pair to ensure connectivity between the Service Provider facing port on the NTU and the Service Provider's equipment port.

If it is a non-standard build, the Service Provider must pay for the following where required to establish a connection between the nearest NBI fibre and a Service Provider chosen Third Party premises:

- installing any new duct / poles
- clearing / fixing existing duct / poles
- new duct / polling and/or fibre build work
- any related civil works

The Service Provider-facing optical port on the WCPE NTU device is the demarcation point. The Service Provider plugs their fibre into one of the available ports on the WCPE device. The actual port is chosen by the Service Provider on their initial order.

1.1.2. Handover using In-Building Handover (IBH) InterConnect

In-Building Handover enables the Service Provider to InterConnect with NBI “across the floor” in the NBI Co-Location site. The Service Provider must have a Co-Location agreement in place with adequate rack space identified and in place, as detailed in the Co-Location agreement.

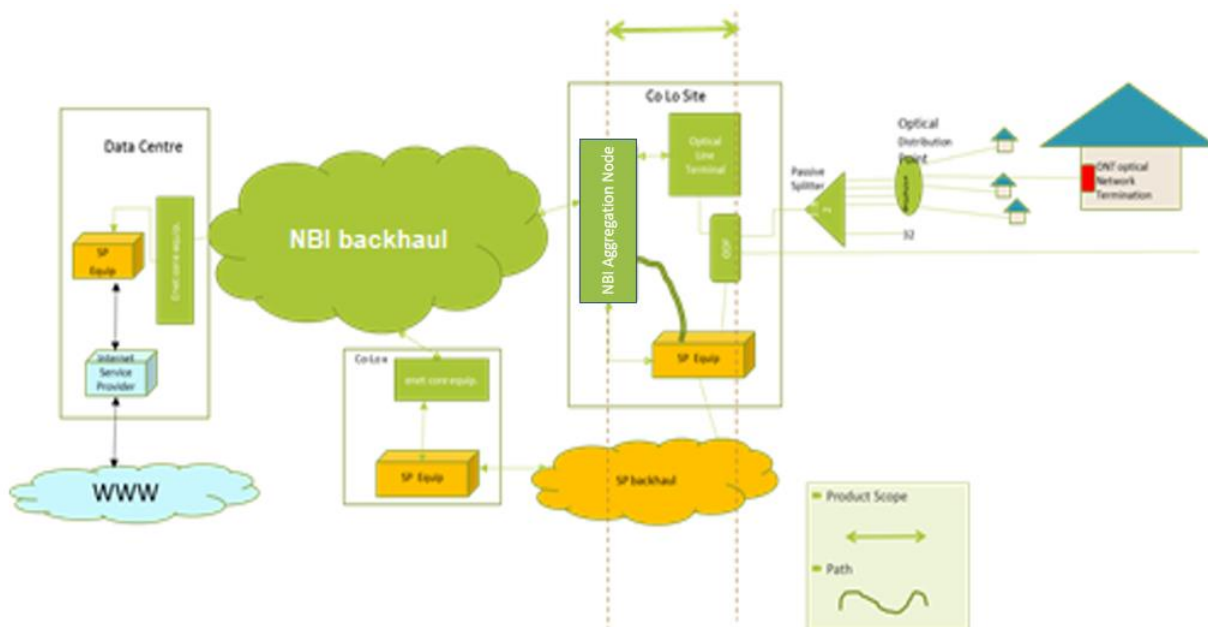

Figure 2: In-Building Handover

A fibre cable is installed between the Service Provider footprint in the Co-Location and the NBI serving aggregation node. Service Provider requests a patch from the Service Provider footprint to a patch panel in the NBI footprint, which forms the demarcation point for the IBH service. IBH is delivered via single mode fibre.

As part of the IBH order, NBI performs a survey within five (5) days of the order to identify and allocate a port on NBI’s patch panel.

Where a Third Party MMR is required (e.g. where the Co-Location site is at the same location as a Data Centre) NBI will present to the MMR. It is the Service Provider’s responsibility to arrange for connection to the MMR from their equipment location and to pay any additional Data Centre charges relating to their equipment installation.

The following media types are available for IBH:

1. an XFP / SFP+ (10G Base LR) for 10Gbit/s InterConnect using an LC connector
2. electrical handover

1.1.3. Handover using In-Span InterConnect (ISH)

In-Span InterConnect enables the Service Provider to InterConnect with NBI in a nominated NBI chamber outside the cabin / Co-Location site. The nominated NBI chamber must be within close proximity of the local Co-Location site.

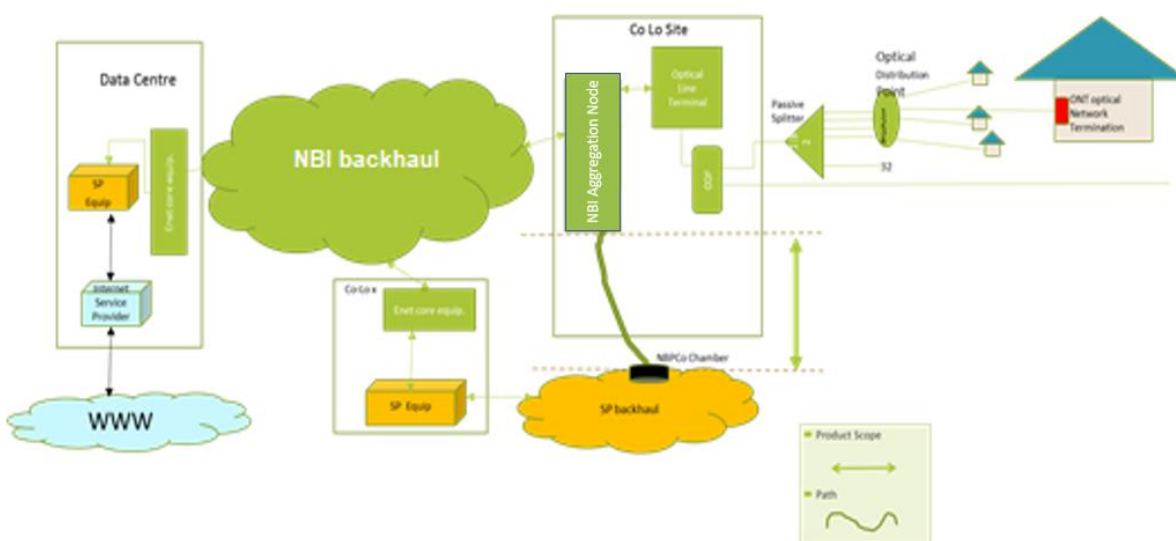

Figure 3: In-Span Handover

Figure 4 below shows the chamber set-up outside an NBI building/cabin Co-Location site.

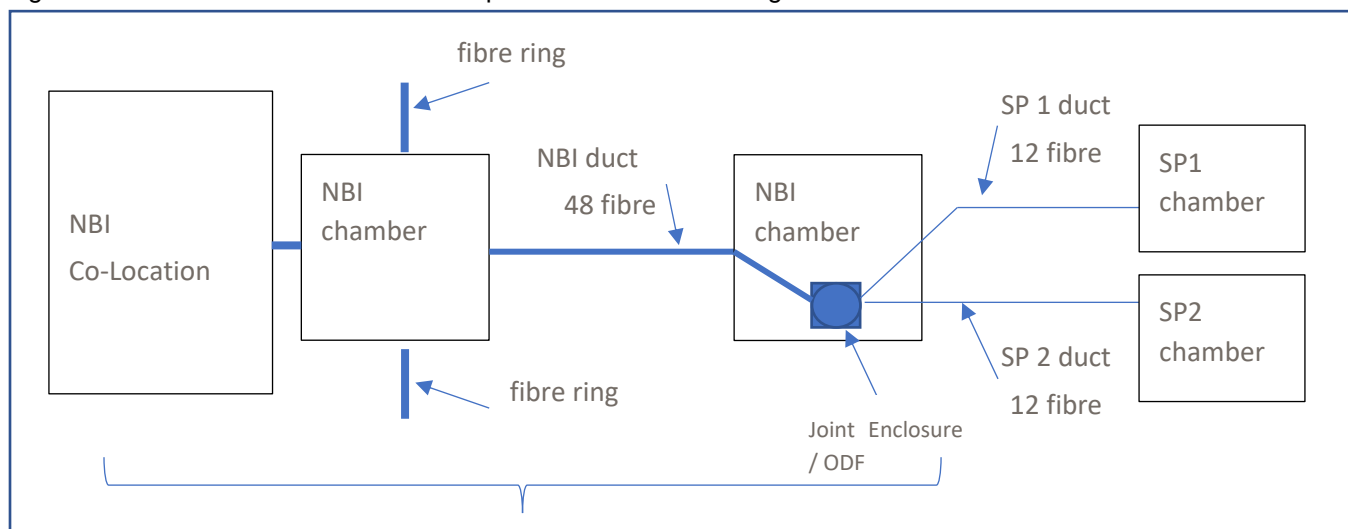

Figure 4: ISH configuration

SUBJECT TO CONTRACT/CONTRACT DENIED

NBI fibre connects from the Co-Location Aggregation Node to a Service Provider fibre at an E-NNI located in an NBI nominated underground chamber. NBI identifies an existing chamber or builds a new chamber within 100 m of the Co-Location site which is used to connect different Service Providers.

NBI provides a fibre splice closure / ODF in the NBI standoff chamber and terminates a minimum of 48 fibre cable on the NBI side of the closure / ODF. The Service Provider installs a 12 fibre cable through to the Service Provider side of the closure / ODF. This cable is no greater than 10 mm in diameter. NBI performs all splicing of fibre within the NBI chamber, including both sides of the closure / ODF (i.e. both NBI and Service Provider fibre).

The Service Provider is responsible for the provision of the duct route to the NBI nominated chamber as well as the core drill from the Service Provider's duct into the NBI chamber which NBI supervises. NBI also provides supervision of the Service Provider duct installation to access the NBI nominated underground chamber. ISH is delivered by means of a single mode long range fibre up to a maximum of 10 km with an option for extended range of up to 40km.

The Service Provider must obtain any required way-leaves associated with the construction of a new Service Provider chamber (as required).

1.2. InterConnect Product Set

This section provides a high-level overview of the InterConnect products available.

1.2.1. Product Set

The NBI InterConnect product set offers the following options.

| Table A – InterConnect Product set | | |
|------------------------------------|---------------------------|-------------------------|
| | 10 Gbit/s InterConnect | 10 Gbit/s LAG / LACP |
| Third Party Premises | ✓ | n/a |
| In-building Handover | ✓ | ✓ |
| In-Span Handover | ✓ | ✓ |

NBI offers both unprotected and protected InterConnect products, as detailed in Section 1.7.

1.2.2. Diversity Protection and LAG

The primary InterConnect path can be protected by ordering a secondary InterConnect with each being delivered via physical (2 routes), cables (2 cables in the same duct) or fibre (2 fibres in the same cable) diversity. These levels of diversity may attract higher charges.

Traffic is managed over the diverse fibre paths using Link Aggregation IEEE 802.3ad which enables grouping of ethernet interfaces at the physical layer to form a single link layer interface, also known as a link aggregation group (LAG) or bundle.

Bitstream and VUA traffic is handed off to the Service Provider over the InterConnect using a pre-defined S-VLAN tag. The S-VLAN is pre-specified by the Service Provider

Link Aggregation Groups (LAG) and Link Aggregation Control Protocol (LACP) are methods to provide more than one link between two nodes. They automate its configuration and maintenance, respectively.

LAG increases link reliability so that with multiple links between two devices, if one fails the other links keep carrying the data and the traffic on the failed link is also transferred to it. This way communication between the links is maintained. LAG also enables traffic load-balancing so that traffic is evenly distributed.

LACP enables the combination of multiple ports/links between two nodes. LACP-enabled ports can automatically configure themselves into trunk groups, without manual configuration or intervention.

If there are more links (between two devices) than is supported by the vendor for LACP, the additional links are placed in stand-by mode and activated automatically when a link fails.

1.3. Key InterConnect Product Attributes

Below is a list of the key attributes that are associated with the InterConnect offering. Some elements such as Protection are optional attributes.

InterConnect circuits are:

- Dedicated to a single end user
- Point to point interconnect circuits with three possible handover configurations, namely;
 - Third Party Premises Handover
 - In-building Handover
 - In-Span Handover
- Available in protected and unprotected modes
- Each InterConnect comprises a Physical Interconnect and a Logical Interconnect

| Specification | Detail |
|--|----------|
| Minimum interface speed of an InterConnect | 10Gbit/s |

1.4. Logical InterConnect service class options

Each InterConnect, irrespective of the handover type, has one logical element which is the same bandwidth as the InterConnect. This logical element is ordered as part of the InterConnect order.

This logical element will have a % EF and % AF bandwidth assigned to it by the Service Provider as part of the InterConnect order. Table C below shows the CIR and PIR on the InterConnect for each Forwarding / Service Class and the maximum amount of EF and AF on a single InterConnect.

Any Bitstream, VUA or managed ethernet traffic arriving at the InterConnect should be marked using the 802.1p markings and will arrive at the aggregation node within the relevant forwarding class / service class.

| Table C – 10 Gbit/s InterConnect | | |
|----------------------------------|--|---|
| Forwarding / Service Class | CIR / PIR (For 10Gbit/s InterConnect) | % that can be ordered / allocated for the specific Forwarding / Service class |
| EF | 3 Gbit/s / 3 Gbit/s | 5%, 10%, 15%, 20%, 30%** |
| AF | 5 Gbit/s / 10 Gbit/s | 5%, 10%, 15%, 20%, 30%, 40%, 50%** |
| BE | 0 Gbit/s / 10 Gbit/s | Balance after EF and AF are added (0-100%) |

**Maximum limit (The combined EF and AF maximum is 5Gbit/s).

IBH and ISH

Standard protection through path diversity on IBH and ISH is achieved using Link aggregation IEEE 802.3ad over dual fibre paths.

- NBI offers 2+0 protection (both links are in active/active mode)
- Interoperability testing is required to ensure correct operation between vendors' equipment.

In a LAG scenario; the second 10 Gbit/s InterConnect is recorded as an LMC (LAG Member Cable). The 10 Gbit/s InterConnect, which is members of the LAG, is configured in active/active mode. Multi-chassis configuration LAGs are not supported on NBI equipment. Only single chassis mode is supported.



Figure 5: InterConnect Protection

SUBJECT TO CONTRACT/CONTRACT DENIED

Note: In order to ensure a full failover capability, with no loss of traffic, the maximum combined bandwidth that should be sent through a 10 Gbit/s IBH or ISH with LAG and LACP protection is a total of 10 Gbit/s. This ensures that, in the event of a failure on one of the LAG ports, the remaining link has sufficient capacity to carry all traffic. There should be minimal service interruption due to the switchover.

TPP

For Third Party Premises InterConnect, NBI offers protection in the form of route disjoint paths (working path and protection paths will use different routes in all sections of the network between the demarcation points of the InterConnect product).

1.5. Forecasting

A Service Provider must submit forecasts to NBI outlining the location and types of InterConnects they wish to order. This is in the form of a 12-month rolling forecast that is required to be submitted on a quarterly basis by each Service Provider.

Full details of the forecasting process is available in the InterConnect Industry Process Manual. This document is available on the NBI website or directly from your account manager.

An order may be rejected for reasons such as:

- (a) any information being inaccurate, incomplete or incorrect or if it is a duplicate order;
- (b) insufficient capacity to fulfil the order

If an order is rejected, NBI notifies the Service Provider automatically with a reason for the rejection. Further details of the ordering process can be found in the Process Manual.

1.6. Ordering and Fault Handling

Ordering of InterConnect products is via the NBI order form.

Full details on all Ordering and Fault Handling processes and where the InterConnect order form can be found are available in the Process Manual. This document is available on the NBI website or directly from the Service Provider's Account Manager.

1.7. InterConnect Capacity Management

The Service Provider is responsible for ensuring that it does not breach the InterConnect capacity specified utilization specified in Table 1 above. A Service Provider can overbook an InterConnect but will not be permitted to send more traffic than the capacity of the InterConnect.

1.8. SLA

Details of the SLA are outlined in the NBI InterConnect SLA document. This document is available on the NBI website or directly from the Service Provider's Account Manager.

Service Providers are able to order the maintenance level required when ordering the InterConnect product or can choose to do so at a later date by submitting a change order.

1.9. Billing

There are connection, rental and one-off charges associated with the InterConnect products. All details of the relevant charges are outlined in the NBI network price list which is available on the NBI website or directly from the Service Provider's Account Manager.

Rental charges are billed annually in advance and include any broken period rentals from the time of installation.

Invoices are issued annually detailing connection, one-off and rental charges payable.

1.10. Pricing and Terms and Conditions

Details regarding pricing for these services are contained within the NBI network price list. Details regarding terms and conditions are contained within the NBI Reference offer and the relevant product Service Schedule contained within. These documents are available on the NBI website or directly the Service Provider's Account Manager.

Schedule 2 – Symmetric Ethernet Services Product Description

Symmetric Ethernet Services (SES) Wholesale Product Overview

The Symmetric ethernet Service (SES) product is an optical fibre product suitable for providing delay and packet loss sensitive services to business customers.

SES enables Service Providers to combine their own transport network with the NBI access network in order to deliver advanced high-speed services to End Users. SES provides a Layer 2 ethernet VLAN-transparent service with Class of Service (CoS) options.

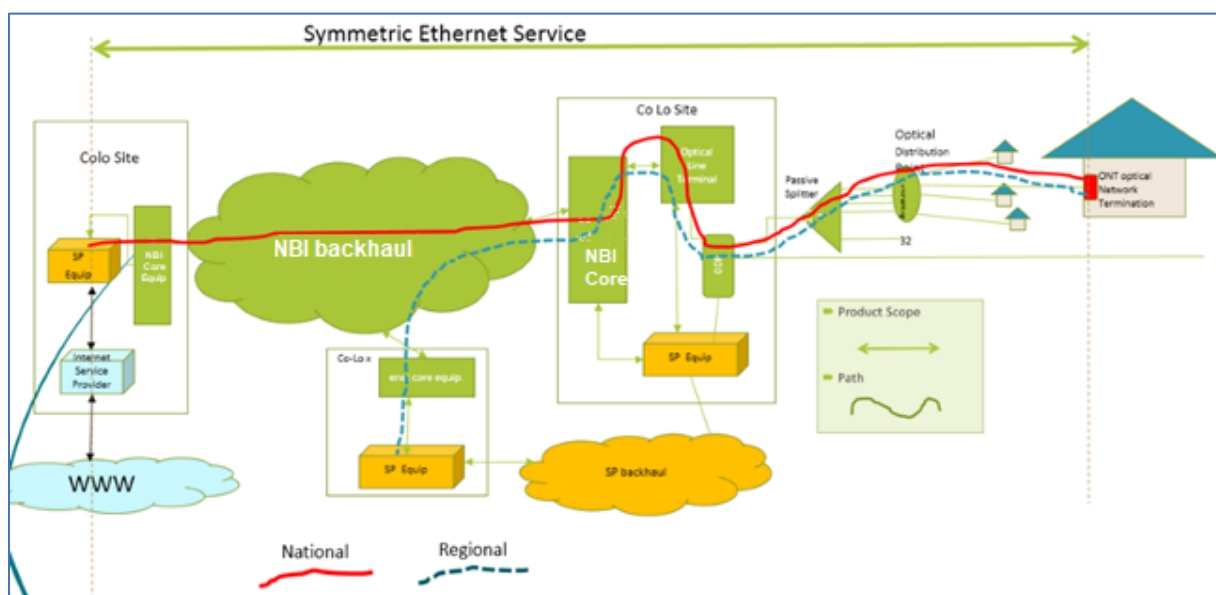

Figure 1: Symmetric Ethernet Services overview

As shown in the diagram above, SES is delivered locally by either a XGS-PON fibre in duplex mode from the UNI of the NTU and/or point to point fibre access network connection to the Co-location PoH-InterConnection and onwards nationally with backhaul transporting the traffic to a carrier InterConnect point.

SES is available in various bandwidths to suit a range of business needs. The fibre technologies used ensure the available speeds are available to all End Users regardless of the length of the access network fibre connection

The table below details the various speeds for Symmetric Ethernet Services (SES) product variants.

| Table A - Symmetric Ethernet Services (SES) products |
|---|
| <i>Product</i> |
| 200 Mbit/s |
| 500 Mbit/s |
| 1 Gbit/s |
| 5 Gbit/s |

1.1. Product Features

The SES product is targeted primarily at the SME and larger business markets and provides Service Providers with the capability to develop their own E-Line and E-LAN type services to meet their End User needs. These include:

- Symmetrical product profiles
- Traffic based Class of Service (CoS) support to enable traffic prioritisation
- Single mode, all fibre network, supporting individual customer services up to 10 Gbit/s
- Active network management to guarantee high-quality service availability
- Support of 100 MAC addresses per layer 2 circuit
- 1 Gbit/s Optical
- Radial distance fibre reach of 4 km (1000Base-LX) and 30 km (1000Base-ZX)
- One S-VLAN per SES logical access (Individual VLAN per Access)
- Hand overs to Service Provider in Dublin using Layer 2 aggregated IEEE 802.1ad InterConnect
- Single point of handover to Service Providers at an agreed location
- RJ45 default hand over on End User's NTU port

1.2. Product Components

The SES product is made of two components:

- Logical: Individual VLAN connection from the NTU through the network and across the InterConnect Link to the Service Provider
- Physical: Connects the OLT port directly through to the NTU in the End User's premises

The SES product provides connectivity (both physical and logical) from a Service Provider's End User premises to a nominated PoH (CSH, ISH or IBH).

1.2.1. Logical Component

Provision of the SES is dependent on the presence of an InterConnect Product connection from the PoH to the Service Provider's network. The InterConnect Product is a separate product.

When the Service Provider orders service to the End User, a unique unicast S-VLAN is established between the End User location and the relevant PoH on the circuit. The S-VLAN allows the Service Provider to implement enhanced traffic management functionality for their customer to maintain end-to-end class of service by setting the 802.1p bit according to the appropriate traffic class for the traffic type.

Logical connectivity links each individual customer connected to the various Service Provider's Points of Presence (POP) within the NBI Aggregation Network Area and onward to the InterConnect Product Link.

A C-VLAN refers to a client-side VLAN, while an S-VLAN refers to a service layer VLAN of operators.

The VLAN ID must be provided during order submission and will be validated by NBI as being within the range defined for the Service Provider. Each individual VLAN in the assigned range can be separately associated with the service instance at each PoH in the NBI network.

The Service Provider is required to tag traffic with the assigned VLAN ID. NBI will direct traffic towards the correct S-VLAN using MAC address learning. The maximum number of MAC addresses available within each Symmetric Ethernet Service product is set to 100.

The logical connection preserves C-VLAN (if present) from the End User NTU and presents it on a Service Provider InterConnect Product at the PoH where 802.1Q support is provided on the NBI NTU.

When ordering SES, the Service Provider must select the billing contract it should be associated with and must also nominate a VLAN from a pre-assigned range within the Service Provider domain. Upon acceptance of the order, the nominated VLAN is assigned to the nominated billing account. A Service Provider can establish multiple billing contracts / domains for Invoice and traffic separation.

1.2.2. Physical Component

The physical access is delivered on a single mode fibre connection to the End User premises, terminated on an NTU provided by NBI. The SES NTU (the WCPE) provides both optical and electrical interfaces. The NTU is managed by and remains the property of NBI and the End User ethernet interface is the service demarcation point. Any equipment beyond this point is responsibility of the Service Provider / End User. The Service Provider must provide their own router or other CPE necessary to provide End User services in the premises.

The NBI physical network termination point InterConnect Product for a SES can be provided as an IBH, ISH or TPP (or CSH), and is the E-NNI at the PoH to a Service Provider. The physical SES connection supports one SES logical connection via each UNI port (optical or electrical) on an NBI site to the Service Provider nominated POH. The physical access is the fibre connection from the NBI location to the physical port on the serving NBI active PoH. The NBI network termination point is defined as the User Network Interface (UNI) port. The UNI port is located on the NBI NTU.

1.3. Responsibilities

NBI is responsible for acquiring the public wayleave for civil infrastructure elements of the service assigning the VLAN identifiers on the Layer 2 aggregated InterConnect corresponding to the desired ethernet bandwidth.

The customer is responsible for allocating adequate rack space for installation of fibre patch panel and the NTU provisioning a clean protected power supply for the NTU shaping the traffic in line with the purchased traffic profile

1.4. In-Building Handover (IBH)

IBH is available to a Service Provider currently availing of the Physical Co-Location Service at the PoH. For a SES IBH, a fibre cable is installed between the Service Provider footprint and the serving NBI active PoH.

The User Network Interface (UNI) port on the NBI NTU located in a Service Provider co-location rack.

1.5. In Span Handover (ISH)

For a SES IBH, the PoH is at the Service Provider's chamber outside the NBI cabin or exchange.

1.6. SES Physical Access Diversity

For Physical Access Diversity, NBI offers two options. Primary physical option and secondary physical option.

SES physical access diversity enables the Service Provider to order a secondary diverse SES physical circuit between the End User NTU to a physical port on the active PoH. A Service Provider can switch traffic from the primary SES physical circuit to the secondary diverse SES physical circuit in the event of a fault occurring on the primary SES physical circuit. This provides Service Providers and their End Users with a

level of access resilience on SES physical circuits. The physical access is delivered on a fibre cable from the NBI network to a Service Provider PoH.

For Dual NTU/Single active PoH/Dual Fibre/Dual Duct, where the physical network can support it, two separate SES physical circuits are implemented between two NTUs located at the End User site to two physical ports on the same serving active PoH. Both SES circuits are active, and both fibre paths are located in separate ducts.

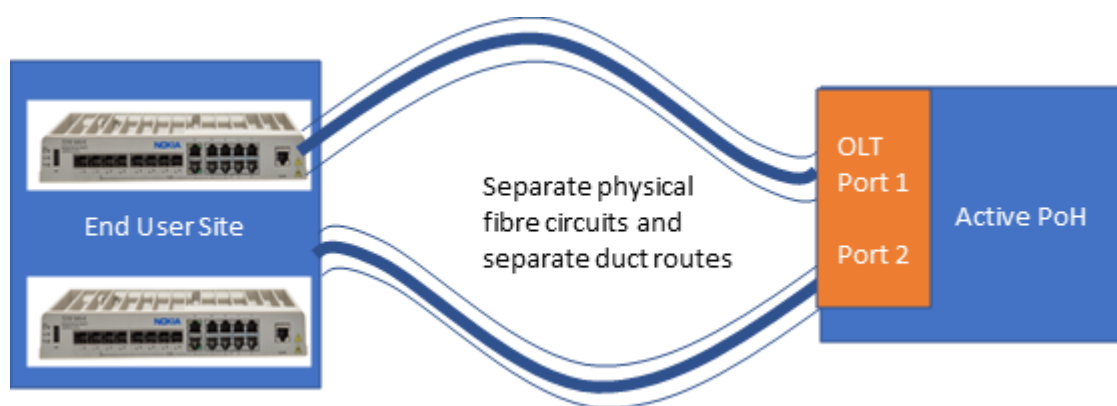

Figure 1: SES Physical Access Diversity

The Service Provider controls the failover between the two SES physical circuits through CPE which ensures switch-over from one SES physical circuit to the other in the event of a failure occurring on one SES physical circuit.

It is the responsibility of the Service Provider to provide CPE with the relevant functionality which ensures that should a fault occur on either SES physical circuit, all traffic will be re-routed onto the other SES physical circuit.

1.7. Bandwidth Management

The SES logical connection can be configured as an uncontended connection where the SES and its associated InterConnect are served off the same active PoH. The NBI active PoH is a non-blocking device and therefore the Service Provider may capacity manage the InterConnect to ensure that it is not overbooked, i.e. that the sum of the SES bandwidths do not exceed the Bandwidth on the InterConnect. In this scenario Class of Service (CoS) is not required on the SES as the connection is uncontended and is not carried across the NBI core network

Conversely, the Service Provider may capacity manage the InterConnect which may result in the InterConnect being overbooked, i.e. that the sum of the SES bandwidths exceeds bandwidth on the InterConnect. In this scenario CoS may be required on the SES and the required level of circuit-based class of service should be specified by the Service Provider.

1.8. Class of Service

Class of Service provides the quality assurance needed for the delivery of differentiated services such as voice, priority data, security or other services. For traffic control and flow there is one master tunnel (VLAN) per Service Provider with multiple “quality tunnels” sitting within the master tunnel. Service Providers have full control over which services have priority on the network.

All traffic carried on the NBI network will be assigned to one of two Class of Service (CoS) queues as set out below:

- Expedited Forwarding (EF)
- Best Effort (BE)

If purchased, the Service Provider can dynamically map their End User traffic to these categories as desired. This provides a Service Provider with the ability to manage and prioritise their upstream and downstream traffic. Upstream and downstream traffic should be marked using 802.1p markings which is mapped into the above queues.

The EF and BE traffic permitted for each product profile is set out below in Table B:

| Table B – Class of Service | | | | |
|---|-------|--------|--------|--------|
| | COS | | | |
| XGS-PON Product (local and national versions) | 0% EF | 10% EF | 20% EF | 50% EF |
| 200 Mbit/s | yes | yes | yes | yes |
| 500 Mbit/s | yes | yes | yes | yes |
| 1 Gbit/s | yes | yes | yes | yes |
| 5 Gbit/s | yes | yes | yes | yes |

1.9. Backhaul

The Service Provider must provide their own backhaul facilities to connect their network directly at each Point of Handover (PoH). All traffic from SES End Users within the PoH area is handed over at the POH, and the Service Provider is responsible for the transport of that traffic from the POH to their own core network. Service Providers can choose any method of backhaul from any provider, including self-supply.

1.10. Ordering

The SES products are ordered via the NBI order form on the Service Provider portal. The Service Provider can use the standard eligibility functionality to confirm whether the network has been rolled out to each individual premises’ address. This will enable Service Providers to identify those End Users who can avail of the SES product.

NBI publishes its deployment plan to give Service Providers advanced notice of the target dates of network completion in each locality. This enables Service Providers to plan their own sales and marketing campaigns.

SES products can be ordered once a Deployment Area is enabled for fibre services. In order to provide local SES service in a launched designated area, the Service Provider must have the necessary InterConnect (s) in place and have the required VLAN(s) provisioned and tested. The SES SLA details the milestones and timeframe targets associated with a connection. Following the successful completion of the SES order, the Service Provider can request changes to the service and migrate between the various SES products.

1.11. Installation Pricing

The installation process involves the physical installation of the fibre and NTU at the Customer end premises and all instances are subject to survey and availability. SES installs can be categorised as follows:

1.1.1. Standard Installation

Standard Installation pricing applies where the initial survey indicates the SES connection can be delivered as a standard FTTH connection to the premises. In these cases, a standard delivery time frame as set out in the SLA will apply. Both connection and rental charges are set out in the price list. The final service commissioning is completed via a customer appointment.

All SES orders are subject to full site survey. The standard installation price applies when the End User premises is served within the limits of a standard FTTH application. The connection to the End User's premises is installed, where possible, following the route of the electrical connection to the premises. A suitable point of entry into the premises is established and the fibre terminated in an internal NTU box.

1.1.2. Non-Standard Installation

Non-Standard pricing applies where the survey indicates that additional build work is required for connection (duct, poles, internal cable runs etc.). A non-standard delivery timescale forecast and quotation is provided. Connection and rental charges are set out in the price list. The final service commissioning is completed via a customer appointment. The Service Provider has the option to accept or reject this additional charge and is free to cancel the order without a cancellation fee.

1.12. Commercial Terms

There are connection and rental charges associated with Symmetric Ethernet Service Products. Once an order is completed, billing shall commence in the next billing cycle.

All prices for the various products are provided in the SES Price List as detailed in Schedule 5 of this document.

The terms and conditions associated with SES are detailed in the InterConnect and SES Reference Offer.

Schedule 3 – InterConnect and SES Product Billing

Connection, rental and one-off charges exist for all NBI InterConnect and SES Products. All details of the relevant charges are outlined in the InterConnect and SES price lists which are available on the website, within Schedules 4 and 5 of this Reference Offer or directly from the Service Provider's NBI Account Manager .

Rental charges are billed annually in advance and include any broken period rentals (charged on a pro-rata basis) from the time of installation. A one-year minimum period of service is applicable to all InterConnect and SES orders.

Invoices are issued annually detailing connection, one-off, Managed Service (if applicable) and rental charges payable. The InterConnect and SES Billing details are described in full as part of the NBI Process Manual and are published on the NBI Website.

Schedule 4 – InterConnect Price List

This Price List sets out the charges applicable to the InterConnect product only. The Price List is also published on the NBI website. For information on pricing for other NBI product sets, please visit the NBI website or consult with your NBI Account Manager.

The prices may increase or decrease in accordance with the provisions of this Reference Offer. All pricing changes go through the defined NBI change management process in accordance with the rules of the Project Agreement in place between NBI and the DCCAE and are reflected in the published NBI InterConnect Products Price List.

All InterConnect types can be ordered via the NBI order form and are available in three variants:

- Third Party Premises (TPP) Handover, also called Customer Sited Handover (CSH)
- In-Building Handover (IBH)
- In-Span Handover (ISH)

All charges in this Price List are exclusive of VAT and are listed in EURO.

| Table A – InterConnect Product pricing | | | | |
|--|--|----------------|--------------|-----------------|
| Charge Ref | Charge Description | Effective From | Effective To | Wholesale Price |
| IC1.0 | 10 Gbit/s InterConnect Annual Rental IBH & ISH | 01/04/2020 | - | €195 |
| IC1.1 | 10 Gbit/s InterConnect Setup IBH & ISH | 01/04/2020 | - | €2,000 |
| IC2.0 | 10 Gbit/s InterConnect Annual Rental CSH | 01/04/2020 | - | €2,100 |
| IC2.1 | 10 Gbit/s InterConnect Setup* CSH | 01/04/2020 | - | €1,250 |

* Diversity routing is available for CSH interconnects but is dependent on a detailed survey / design. IBH & ISH diversity is the responsibility of the Service Provider.

Schedule 5 – SES Price List

This Price List sets out the charges applicable to the SES product only. The Price List is also published on the NBI website. For information on pricing for other NBI product sets, please visit the NBI website or consult with your NBI Account Manager.

The prices may increase or decrease in accordance with the provisions of this Reference Offer. All pricing changes go through the defined NBI change management process in accordance with the rules of the Project Agreement in place between NBI and the DCCAE and are reflected in the published NBI SES Wholesale Products Price List.

| Table A – SES Product pricing | | | | |
|-------------------------------|---|----------------|--------------|--------------------------|
| Charge Ref | Charge Description | Effective From | Effective To | Wholesale Price (Annual) |
| Connection Charges | | | | |
| SES1.17 | Symmetric Local Connection - Standard | 01/04/2020 | - | € 1,190.00 |
| SES1.18 | Symmetric Local Connection – Non-Standard | 01/04/2020 | - | variable |
| Rental Charges | | | | |
| SES1.1 | Symmetric Local 200 Rental (100% BE) | 01/04/2020 | - | € 5,400.00 |
| SES1.2 | Symmetric Local 500 Rental (100% BE) | 01/04/2020 | - | € 6,800.00 |
| SES1.3 | Symmetric Local 1000 Rental (100% BE) | 01/04/2020 | - | € 8,300.00 |
| SES1.4 | Symmetric Local 5000 Rental (100% BE) | 01/04/2020 | - | € 12,200.00 |
| SES1.5 | Symmetric Local 200 Rental (10%EF) | 01/04/2020 | - | € 7,000.00 |
| SES1.6 | Symmetric Local 500 Rental (10%EF) | 01/04/2020 | - | € 9,400.00 |
| SES1.7 | Symmetric Local 1000 Rental (10%EF) | 01/04/2020 | - | € 11,500.00 |
| SES1.8 | Symmetric Local 5000 Rental (10%EF) | 01/04/2020 | - | € 16,900.00 |

SUBJECT TO CONTRACT/CONTRACT DENIED

| | | | | |
|---------|--|------------|---|-------------|
| SES1.9 | Symmetric Local 200 Rental (20%EF) | 01/04/2020 | - | € 8,500.00 |
| SES1.10 | Symmetric Local 500 Rental (20%EF) | 01/04/2020 | - | € 12,000.00 |
| SES1.11 | Symmetric Local 1000 Rental (20%EF) | 01/04/2020 | - | € 14,700.00 |
| SES1.12 | Symmetric Local 5000 Rental (20%EF) | 01/04/2020 | - | € 21,800.00 |
| SES1.13 | Symmetric Local 200 Rental (50%EF) | 01/04/2020 | - | € 13,500.00 |
| SES1.14 | Symmetric Local 500 Rental (50%EF) | 01/04/2020 | - | € 20,100.00 |
| SES1.15 | Symmetric Local 1000 Rental (50%EF) | 01/04/2020 | - | € 24,800.00 |
| SES1.16 | Symmetric Local 5000 Rental (50%EF) | 01/04/2020 | - | € 37,000.00 |
| SES1.19 | Symmetric National 200 Rental (100% BE) | 01/04/2020 | - | € 6,400.00 |
| SES1.20 | Symmetric National 500 Rental (100% BE) | 01/04/2020 | - | € 9,700.00 |
| SES1.21 | Symmetric National 1000 Rental (100% BE) | 01/04/2020 | - | € 11,600.00 |
| SES1.22 | Symmetric National 5000 Rental (100% BE) | 01/04/2020 | - | € 16,500.00 |
| SES1.23 | Symmetric National 200 Rental (10%EF) | 01/04/2020 | - | € 8,400.00 |
| SES1.24 | Symmetric National 500 Rental (10%EF) | 01/04/2020 | - | € 13,000.00 |
| SES1.25 | Symmetric National 1000 Rental (10%EF) | 01/04/2020 | - | € 15,600.00 |
| SES1.26 | Symmetric National 5000 Rental (10%EF) | 01/04/2020 | - | € 22,500.00 |
| SES1.27 | Symmetric National 200 Rental (20%EF) | 01/04/2020 | - | € 10,300.00 |
| SES1.28 | Symmetric National 500 Rental (20%EF) | 01/04/2020 | - | € 16,200.00 |
| SES1.29 | Symmetric National 1000 Rental (20%EF) | 01/04/2020 | - | € 19,600.00 |
| SES1.30 | Symmetric National 5000 Rental (20%EF) | 01/04/2020 | - | € 28,600.00 |

SUBJECT TO CONTRACT/CONTRACT DENIED

| | | | | |
|---------|--|------------|---|-------------|
| SES1.31 | Symmetric National 200 Rental (50%EF) | 01/04/2020 | - | € 16,600.00 |
| SES1.32 | Symmetric National 500 Rental (50%EF) | 01/04/2020 | - | € 26,400.00 |
| SES1.33 | Symmetric National 1000 Rental (50%EF) | 01/04/2020 | - | € 32,400.00 |
| SES1.34 | Symmetric National 5000 Rental (50%EF) | 01/04/2020 | - | € 47,700.00 |